



revision B1 april 2007



installation instructions and safety information



LISTED 18TC
UL 325
UL 991

CLASS I, CLASS II, CLASS III and CLASS IV

vehicular gate operator

G-5

PARTS DIAGRAM

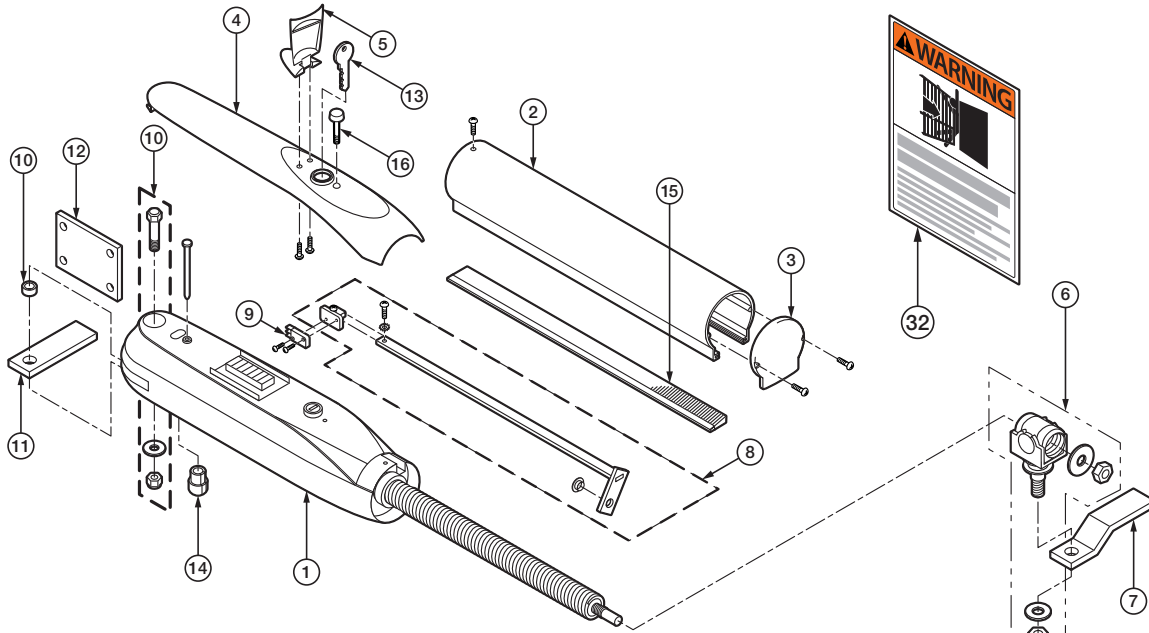

Item	Description	Part No.
1	Unit, Motor/Lead Screw	VAG5
2	Cover, Lead Screw	VAG5CLS
3	End Cap, Lead Screw Cover	VAG5ECC
4	Cover, Terminal	21990
5	Door, Access	6LUXS
6	Carrier, Lead Screw, with hardware	VAG5CGH
7	Mounting Bracket, Front	21931
8	Bar, Limit Switch	VAG5LB
9	Limit Switch (2)	VAG5LS
10	Mounting Hardware, Back	VAG5MHB
11	Mounting Bracket, Back	VAG5MBB
12	Backing Plate, Bar Mount (2)	2T365
13	Key, Release	VAG5KR
14	Holder, Cable	VAG5CH
15	Dust Brush (2)	VAG5DB1
16	Thumbscrew, Terminal Block Cover	VAG5TSTC
17	ECU Box (Standard/Industrial)	ECUB / ECUIB
18	Control Board (Single/Master-Slave)	DUPCB10 / DUMSCB10
19	Toroid Transformer, 10 awg	DUTO10
20	EMI Board	DUEMI10
21	Battery (2)	DUBA10
22	Battery Fuse Holder	VABFH
23	Motor Harness	ECUMTHR
24	Power Harness	DUPHC
25	Alarm	DUAL10
26	ECU Access Key	ECUKEY
27	ECU Key Cylinder	ECUKEYC
28	Reset Switch	ECURW
29	Fuse Kit	DUFSK10
30	Radio Antenna Kit	VARAK
31	Strain Relief	DH3/4NMCC
32	Warning Placard	DUWPA

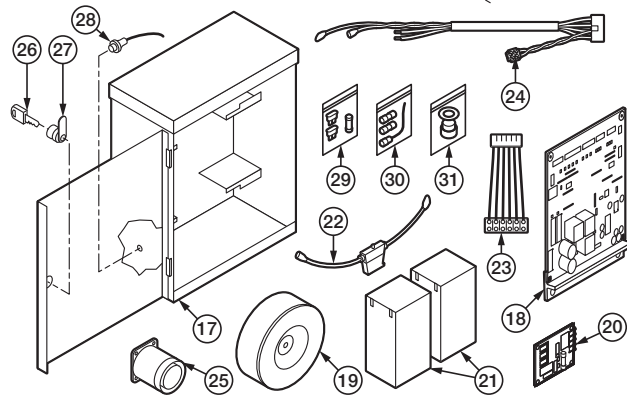

Overall Dimensions

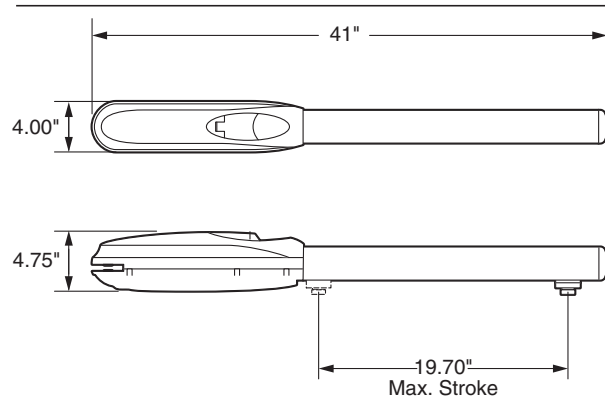

Weight

40 lb.

**WARNING - For Installation
By Qualified Personnel Only.**



TABLE OF CONTENTS

Parts Diagram/Parts List	i
Important Safety Information	
Important Safety Instructions	2
Important Installation Instructions	2-3
Maintenance/General Safety Precautions	4
Terminology	5
Photo Beam (non-contact sensor) Installation	6
Edge Sensor (contact sensor) Installation	7
Manual Release	7
Audible Alarm Reset Switch Installation	8
Warning Placard Installation	8
Important Installation Information	9
Specifications	9
Plan of Installation – Open Inside	10
Plan of Installation – Open Outside	11
Gate Operator Installation	
Step 1 through 5 – Operator Installation	12-13
Step 6 through 8 – Limit Switch Setup	14
Opening/Closing Setup	15
Reference Wiring Diagram; Limit Switch Connections	15
Control Box Installation	16
Electrical Installation	
Electrical Installation (120/220 VAC)	17
Single Unit Connections	18
Master/Slave Connections	19
Vehicular Loop Detector Installation	
Loop Layout Diagrams	20
Installation Guidelines	21
Accessory Connections	
Open Commands; Safety Connections	22
Radio Receiver	23
Viking Electromagnetic Lock	24
Magnetic Lock; Solenoid; Guard Station	25
Special Features	
Intelligent Obstruction Sensor (Primary Entrapment Protection)	26
Fail Safe/Fail Secure Operation; Hold Open Timer	27
Gate Overlap Setting	28
Solar Panel Installation	29
Viking Hinge	30
Troubleshooting	31-33



IMPORTANT SAFETY INFORMATION

WARNING - Not following these instructions may cause severe injury or death to persons.

IMPORTANT SAFETY INSTRUCTIONS

WARNING – To reduce the risk of severe injury or death:

1. READ AND FOLLOW ALL INSTRUCTIONS.
2. Never let children operate or play with gate controls. Keep the remote control away from children.
3. Always keep people and objects away from the gate. **NO ONE SHOULD CROSS THE PATH OF THE MOVING GATE.**
4. Test the gate operator monthly. The gate **MUST** reverse on contact with a rigid object or when an object activates the non-contact sensors. After adjusting the force or the limit of travel, retest the gate operator. Failure to adjust and retest the gate operator properly can increase the risk of injury or death.
5. Use the manual release only when the gate is not moving.
6. **KEEP GATES PROPERLY MAINTAINED.** Read the owner's manual. Have a qualified service person make repairs to gate hardware.
7. The entrance is for vehicles only. Pedestrians must use separate entrance.
8. **Every gate operator installation MUST have secondary protection devices against entrapment, such as edge sensors and photo beams more in particularly in places where the risk of entrapment is more likely to occur.**
9. SAVE THESE INSTRUCTIONS.

IMPORTANT INSTALLATION INSTRUCTIONS

1. Install the gate operator only when:
 - a) The operator is appropriate for the construction of the gate and the usage Class of the gate (refer to page 5),
 - b) All openings of a horizontal slide gate are guarded or screened from the bottom of the gate to a minimum of 4 feet (1.22 m) above the ground to prevent a 2-1/4 inch (57.2 mm) diameter sphere from passing through the openings anywhere in the gate, and in that portion of the adjacent fence that the gate covers in the open position,
 - c) **ALL EXPOSED PINCH POINTS ARE ELIMINATED OR GUARDED, AND**
 - d) **GUARDING IS SUPPLIED FOR EXPOSED ROLLERS.**
2. The operator is intended for installation only on gates used for vehicles. Pedestrians must be supplied with a separate access opening. The pedestrian access opening shall be designed to promote pedestrian usage. Locate the gate such that persons will not come in contact with the vehicular gate during the entire path of travel of the vehicular gate.
3. The gate must be installed in a location so that enough clearance is supplied between the gate and adjacent structures when opening and closing to reduce the risk of entrapment. Swinging gates shall not open into public access areas.
4. The gate must be properly installed and work freely in both directions prior to the installation of the gate operator. Do not over-tighten the operator clutch or pressure relief valve to compensate for a damaged gate.
5. The gate operator controls must be placed so that the user has full view of the gate area when the gate is moving **AND AWAY FROM THE GATE PATH PERIMETER,**



IMPORTANT SAFETY INFORMATION

WARNING - Not following these instructions may cause severe injury or death to persons.

IMPORTANT INSTALLATION INSTRUCTIONS Continued

6. Controls intended for user activation must be located at least six feet (6') away from any moving part of the gate and where the user is prevented from reaching over, under, around or through the gate to operate the controls. Outdoor or easily accessible controls shall have a security feature to prevent unauthorized use.
7. The Stop and/or Reset button must be located in the line-of-sight of the gate. Activation of the reset control shall not cause the operator to start.
8. All warning signs and placards must be installed where visible in the area of the gate. A minimum of two placards shall be installed. A placard is to be installed in the area of each side of the gate and be visible to persons located on the side of the gate on which the placard is installed.
9. **For gate operators utilizing a non-contact sensor (Photo beam or like) in accordance with section 31.1.1 of the UL325 standard:**
 - a) **See instructions on the placement of non-contact sensors for each Type of application (refer to page 6),**
 - b) **Care shall be exercised to reduce the risk of nuisance tripping, such as when a vehicle, trips the sensor while the gate is still moving, and**
 - c) **One or more non-contact sensors shall be located where the risk of entrapment or obstruction exists, such as the perimeter reachable by a moving gate or barrier (refer to page 6).**
 - d) **Use only Omron E3K-R10K4 photoelectric eye to comply with UL325**
10. **For a gate operator utilizing a contact sensor (Edge sensor or like) in accordance with section 31.1.1 of the UL325 standard:**
 - a) **One or more contact sensors shall be located where the risk of entrapment or obstruction exists, such as at the leading edge, trailing edge, and post mounted both inside and outside of a vehicular horizontal slide gate (refer to page 7).**
 - b) **One or more contact sensors shall be located at the bottom edge of a vehicular vertical lift gate.**
 - c) **One or more contact sensors shall be located at the pinch point of a vehicular vertical pivot gate.**
 - d) **A hardwired contact sensor shall be located and its wiring arranged so that the communication between the sensor and the gate operator is not subjected to mechanical damage.**
 - e) **A wireless contact sensor such as one that transmits radio frequency (RF) signals to the gate operator for entrapment protection functions shall be located where the transmission of the signals are not obstructed or impeded by building structures, natural landscaping or similar obstruction. A wireless contact sensor shall function under the intended end-use conditions.**
 - f) **One or more contact sensors shall be located on the inside and outside leading edge of a swing gate. Additionally, if the bottom edge of a swing gate is greater than 6 inches (152 mm) above the ground at any point in its arc of travel, one or more contact sensors shall be located on the bottom edge (refer to page 7).**
 - g) **One or more contact sensors shall be located at the bottom edge of a vertical barrier (arm).**
 - h) **Use only Miller Edge Model MGR20 or MGS20 edge sensor to comply with UL325**



IMPORTANT SAFETY INFORMATION

WARNING - Not following these instructions may cause severe injury or death to persons.

MAINTENANCE

Remove the Power Harness from the Control Board (refer to page 17)

- Clean and lubricate the turning pins and gate hinges using the recommended lubricant.
- Clean and lubricate the lead screw using silicon grease.
- Check that all mounting hardware of the gate operator is properly tighten.
- Ensure that the gate moves freely.
- Check for corroded parts and replace if necessary.
- Check the battery for the following:
 - Battery connections must be free of corrosion.
 - Battery voltage must be 26 VDC (fully charged battery).

Reconnect the Power Harness for the Control Board (refer to page 17)

- Check and confirm the proper operation of all safety devices (photoelectric eye, edge sensors or like).
- Check and confirm the operation of all installed accessories.
- Check and confirm the operation of all special features such as the Intelligent Obstruction Sensor, Hold Open Timer (refer to page 20 to 27)
- Check and confirm the operation of the manual release (refer to page 7)
- Verify battery backup functionally by turning off the power source (120 VAC and 220 VAC).
DO NOT FORGET TO TURN ON THE POWER SOURCE AFTER VERIFICATION.

GENERAL SAFETY PRECAUTIONS

The following precautions are an integral and essential part of the product and must be supplied to the user. Read them carefully as they contain important indications for the safe installation, use and maintenance.

- These instruction must be kept and forwarded to all possible future users of the system.
- This product must be used only for that which it has been expressly designed.
- Any other use is to be considered improper and therefore dangerous.
- The manufacturer cannot be held responsible for possible damage caused by improper, erroneous or unreasonable use.
- Avoid operating in the proximity of the hinges or moving mechanical parts.
- Do not enter the path of the moving gate while in motion.
- Do not obstruct the motion of the gate as this may cause a situation of danger.
- Do not allow children to play or stay within the the path of the moving gate.
- Keep remote control or any other control devices out of the reach of children, in order to avoid possible involuntary activation of the gate operator.
- In case of break down or malfunctioning of the product, disconnect from the main power source. Do not attempt to repair or intervene directly, contact only qualified personnel for repair.
- Failure to comply with the above may create a situation of danger.
- All cleaning, maintenance or repair work must be carried out by qualified personnel.
- In order to guarantee that the system works efficiently and correctly it is important to have the manufacturer's instructions on maintenance of the gate and operator carried out by qualified personnel.
- In particular, regular checks are recommended in order to verify that the safety devices are operating correctly.

All installation, maintenance and repair work must be documented and made available to the user.

Installer:

Signature _____

Date _____

Contact: _____



TERMINOLOGY

UL325 Gate Operator Classification

GLOSSARY

RESIDENTIAL VEHICULAR GATE OPERATOR

CLASS I – A vehicular gate operator (or system) intended for use in a home of one-to four single family dwelling, or a garage or parking area associated therewith.

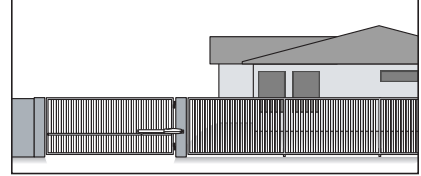

COMMERCIAL/GENERAL ACCESS VEHICULAR GATE OPERATOR

CLASS II – A vehicular gate operator (or system) intended for use in a commercial location or building such as a multi-family housing unit (five or more single family units), hotel, garages, retail store, or other building servicing the general public.

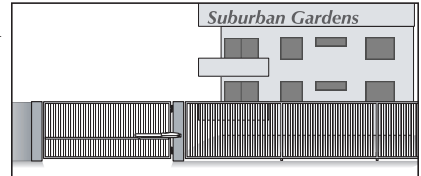

INDUSTRIAL/LIMITED ACCESS VEHICULAR GATE OPERATOR

CLASS III – A vehicular gate operator (or system) intended for use in an industrial location or building such as a factory or loading dock area or other locations not intended to service the general public.

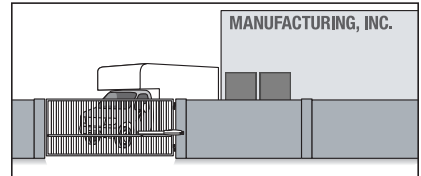

RESTRICTED ACCESS VEHICULAR GATE OPERATOR

CLASS IV – A vehicular gate operator (or system) intended for use in a guarded industrial location or building such as an airport security area or other restricted access locations not servicing the general public, in which unauthorized access is prevented via supervision by security personnel.

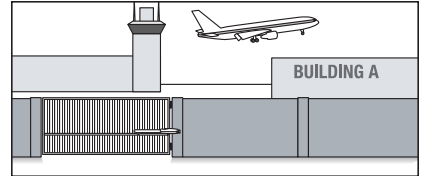

Install the gate operator only when:

The operator is appropriate for the construction of the gate and the Usage Class of the gate.



IMPORTANT SAFETY INFORMATION

WARNING - Not following these instructions may cause severe injury or death to persons.

NOTE - This type of installation DOES NOT reverse the gate all the way back to its limits when the photo-beam is obstructed. This installation is only to protect against entrapment and to comply with UL325.

Photo Beam (non-contact sensor) Installation Secondary Entrapment Protection

Photo beams or like must be installed to reduce the risk of entrapment.

Use only Omron E3K-R10K4 photoelectric eye to comply with UL325

Make the electrical connections of the photoelectric sensor as described here in this page.

Care shall be exercised to reduce the risk of nuisance tripping, such as when a vehicle, trips the sensor while the gate is still moving, and

One or more non-contact sensors shall be located where the risk of entrapment or obstruction exists, such as the perimeter reachable by a moving gate or barrier.

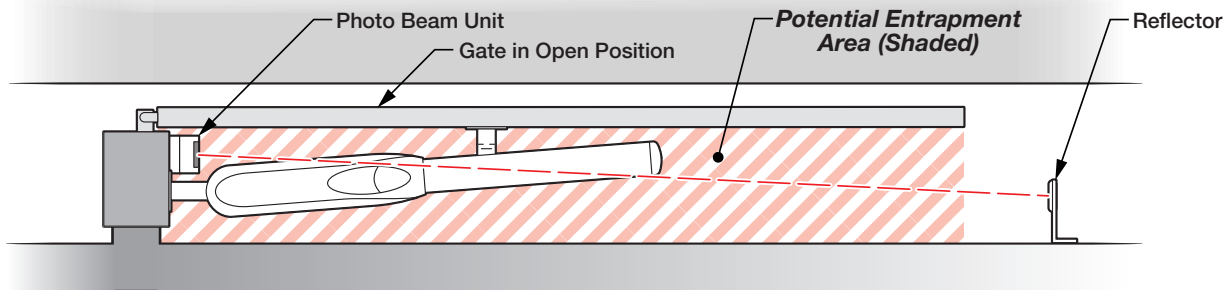
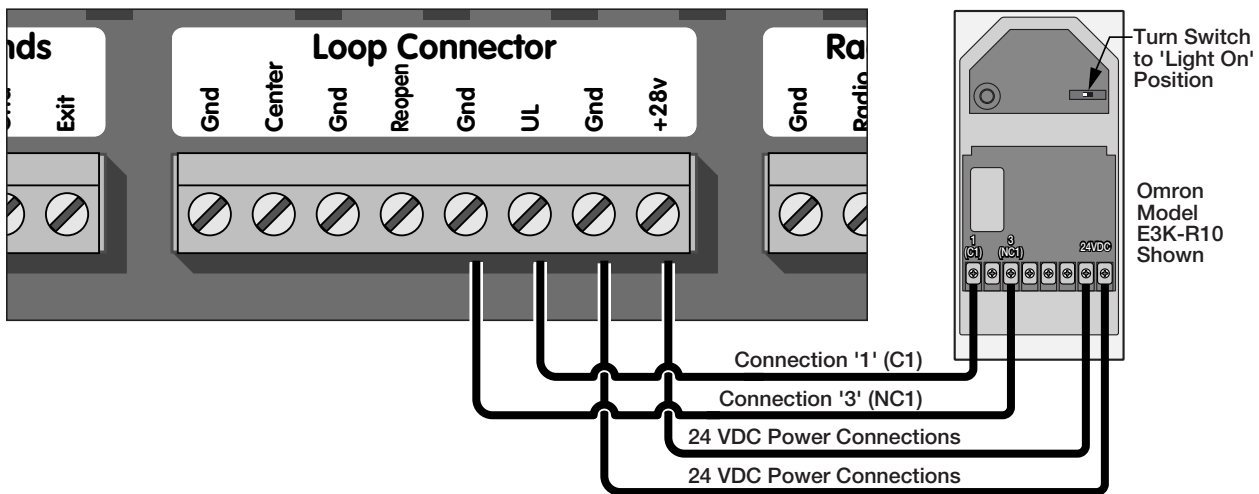

One or more non-contact sensors shall be located where the risk of entrapment or obstruction exists, such as the perimeter reachable by a moving gate or barrier.

Consult the installation manual for the UL325 device (photo beam or like) for detail information about the usage, installation and maintenance



IMPORTANT SAFETY INFORMATION

WARNING - Not following these instructions may cause severe injury or death to persons.

Edge Sensor (contact sensor) Installation

Secondary Entrapment Protection

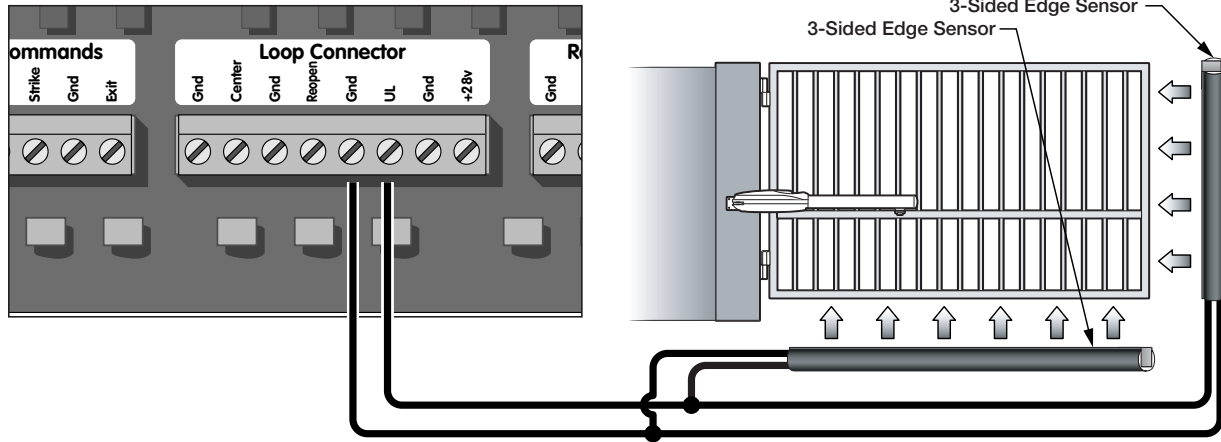

Edge sensor or like must be installed to reduce the risk of entrapment.

Use only Miller Edge 3-sided activation type MGR20 or MDS20 to comply with UL325. One or more contact sensors shall be located on the inside and outside leading edge of a swing gate. Additionally, if the bottom edge of a swing gate is greater than 6 inches (152 mm) above the ground at any point in its arc of travel, one or more contact sensors shall be located on the bottom edge.

1. A hardwired contact sensor shall be located and its wiring arranged so that the communication between the sensor and the gate operator is not subjected to mechanical damage.
2. A wireless contact sensor such as one that transmits radio frequency (RF) signals to the gate operator for entrapment protection functions shall be located where the transmission of the signals are not obstructed or impeded by building structures, natural landscaping or similar obstruction. A wireless contact sensor shall function under the intended end-use conditions.

Manual Release

When manual operation is required:
Insert the key and rotate clockwise. This will allow the gate to be moved manually.

To reengage the gate operator, turn the key counter-clockwise

Attention: Lock and release operations MUST be performed with motor NOT RUNNING.

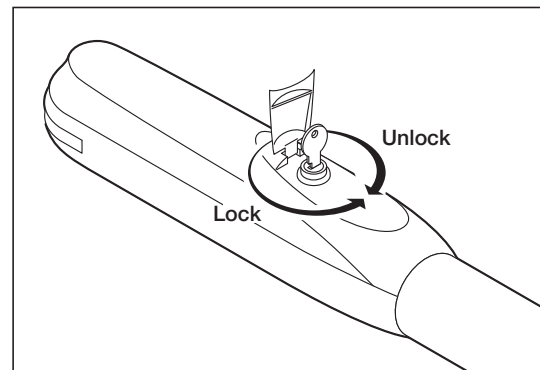

IMPORTANT SAFETY INFORMATION

WARNING - Not following these instructions may cause severe injury or death to persons.

Audible Alarm Reset Switch Installation

Manual Reset for the Audible Alarm

UL325 standard requires an audible alarm to go off after two consecutive events detected by the primary entrapment protection of the gate operator (obstruction sensor). The audible alarm will continue to sound for 5 minutes or until a stop command gets actuated.

The Stop command can be actuated in two different forms

1. Using the Built in Stop switch on the Control Box or
2. Using an External Stop button within the sight of the gate, away from moving parts of the gate and out of reach of children.
3. Controls intended for user activation must be located at least six feet (6') away from any moving part of the gate and where the user is prevented from reaching over, under, around or through the gate to operate the controls. Outdoor or easily accessible controls shall have a security feature to prevent unauthorized use.
4. The Stop and/or Reset button must be located in the line-of-sight of the gate. Activation of the reset control shall not cause the operator to start.

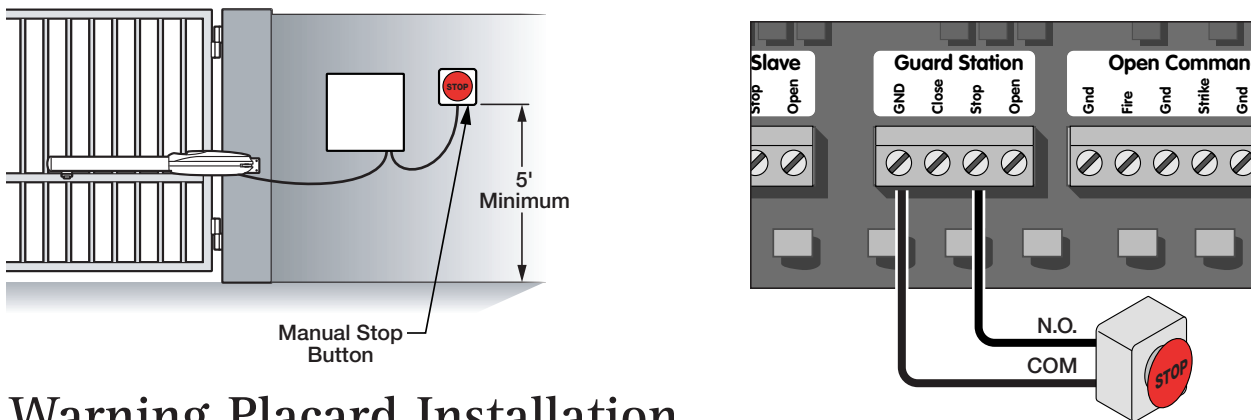

Warning Placard Installation

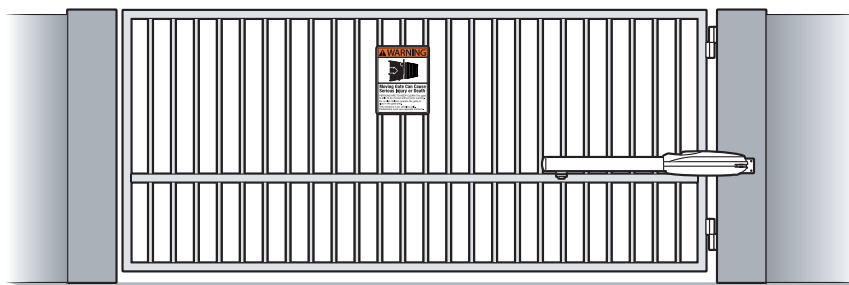

All Warning Signs and Placards must be installed where visible in the area of the gate. A minimum of two placards shall be installed. A placard is to be installed in the area of each side of the gate and be visible.

IMPORTANT INSTALLATION INFORMATION

**CAUTION - FOR USE WITH GATES OF A MAXIMUM OF 16 FT IN LENGTH AND 700 LBS. IN WEIGHT.
WARNING - TO REDUCE THE RISK OF SEVERE INJURY OR DEATH TO PERSONS:**

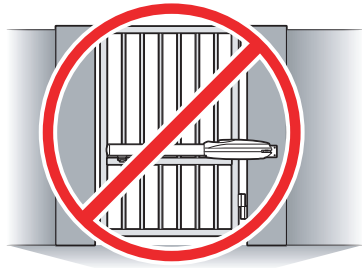

This is NOT a pedestrian gate operator



Do NOT Install the gate operator to lift gates

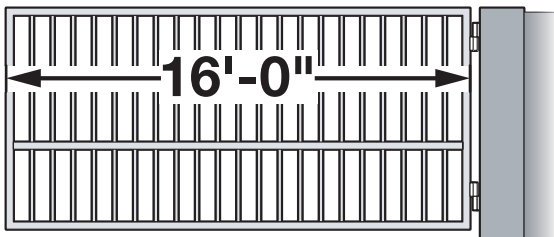

16' maximum gate length

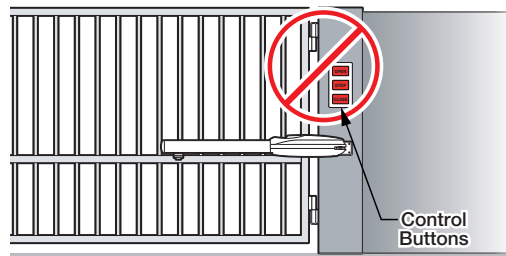

Locate Control Buttons:

1. Within sight of the gate,
2. At a minimum height of 5 feet so small children are not able to reach it, and
3. Away from all moving parts of the gate.

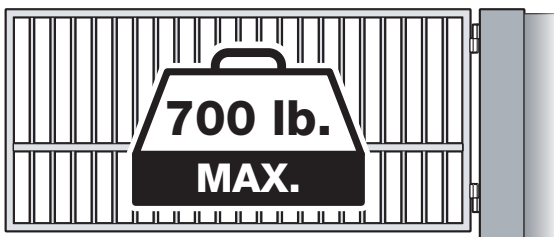

700 pounds maximum gate weight

Specifications

Maximum Gate Length:	16 feet
Maximum Gate Weight:	700 lbs.
Maximum Aperture Angle:	120 deg.
Power Requirements:	120 VAC Single Phase at 2 Amps Or 220 VAC Single Phase at 1 Amp
Operating Temperature:	-20°C (-4°F) to 70°C (158°F)



PLAN OF INSTALLATION - OPEN INSIDE

The gate must be installed in a location so that enough clearance is supplied between the gate and adjacent structures when opening and closing to reduce the risk of entrapment.

Swinging gates shall not open into public access areas.

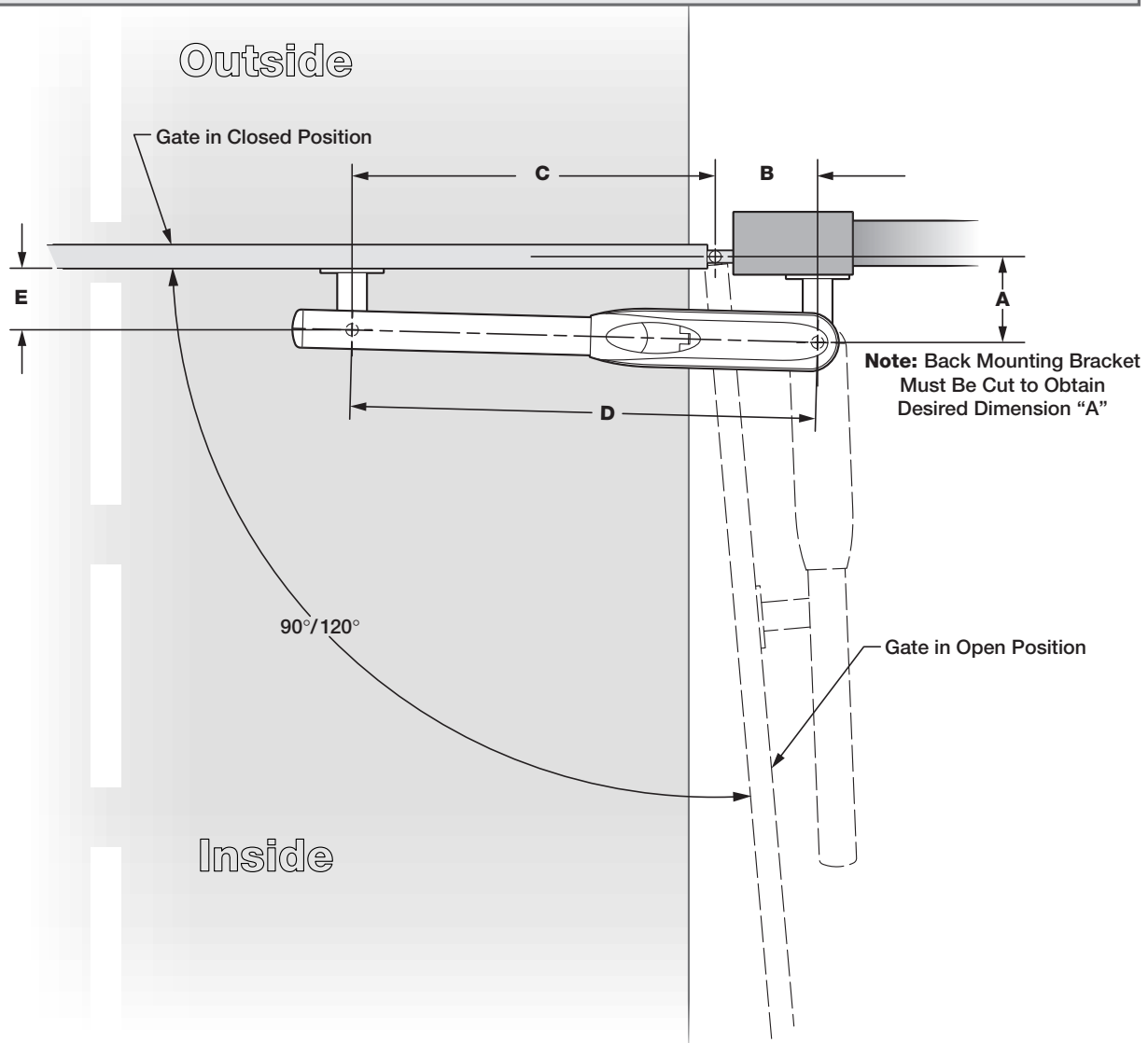

Range	NORMAL INSTALLATION					Opening Time
	A	B	C	D	E	
Option A	6.00	4.50	27	31.5	4.75	14 seconds
Option B	6.625	7.875	28	35.875	4.75	20 seconds

Figure A
Open Inside Plan of Installation

Note: Varying from the dimensions shown may severely affect the speed and performance of the gate operator.



PLAN OF INSTALLATION – OPEN OUTSIDE

The gate must be installed in a location so that enough clearance is supplied between the gate and adjacent structures when opening and closing to reduce the risk of entrapment.

Swinging gates shall not open into public access areas.

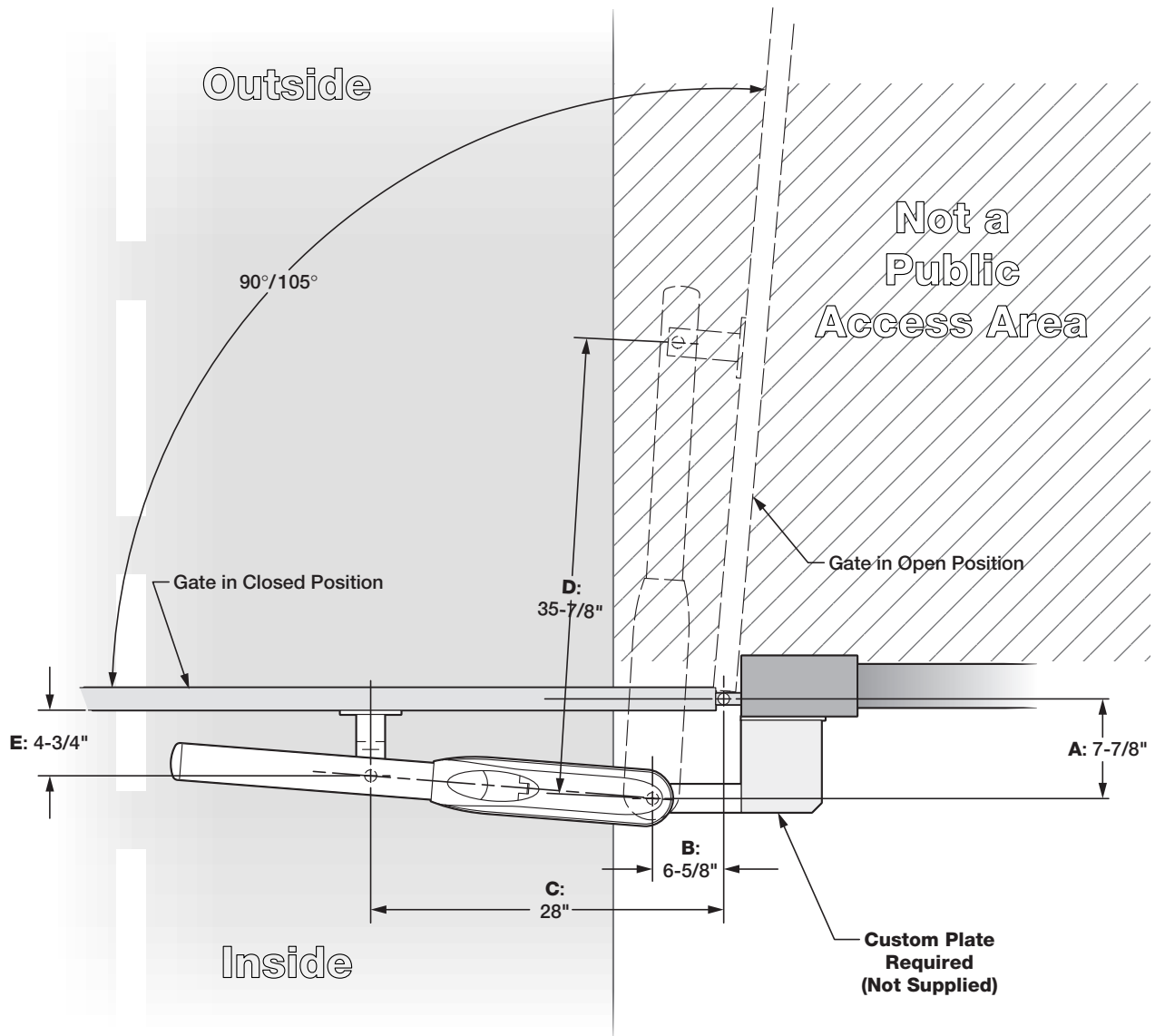

Figure B
Open Outside Plan of Installation

Note: Varying from the dimensions shown may severely affect the speed and performance of the gate operator.



GATE OPERATOR INSTALLATION

CAUTION - If Front Mounting Bar is not welded to a frame member that runs the full length of the gate, the gate operator may damage the gate. Do not weld the bar or backing plate to a few pickets.



STEP 1

Cut the Front Mounting Bar (the offset bar) so that:

The bolt center is 4-3/4" from the inside surface of the gate and 27" to 28" from the gate hinge.

Note: It is recommended to use a frame member across the full width of the gate.

A backing plate is provided for gates of non-ferrous construction. Tack weld the bar in place.

Refer to Figure A or B, page 10 or 11 for proper configuration.

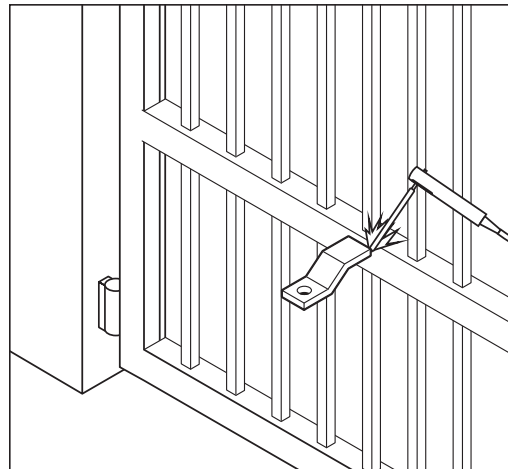

STEP 2

Cut and position the pivot bar according to Figure A or B, page 10 or 11. Tack weld the pivot bracket, ensuring that the two bars are level as shown on the right.

Note: For an Open Outside gate, an additional bracket will need to be fabricated to obtain the proper configuration (see Figure B, page 11).

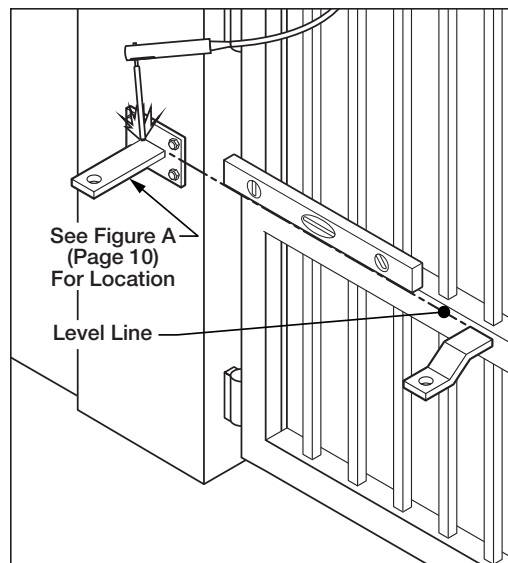

Note: Depending on type of anchor used, it may be required to enlarge the mounting holes in the pivot bracket.



GATE OPERATOR INSTALLATION

Step 3

Remove the Terminal Cover:

- a) Open the plastic flap and
- b) Remove the Thumbscrew.

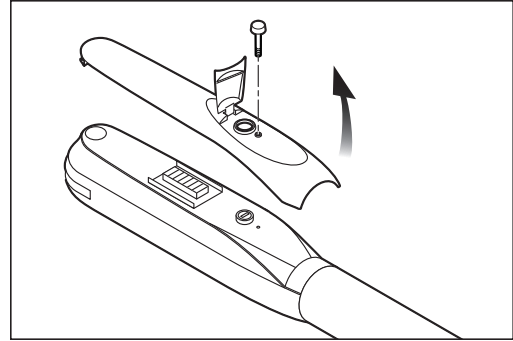

STEP 4

Mount the operator. Perform the Manual Release procedure as shown at the bottom of page 7. The gate can now be moved manually.

Ensure that the gate and gate operator moves freely.

Once it is determined the operator will work properly, remove the operator and complete the welding process.

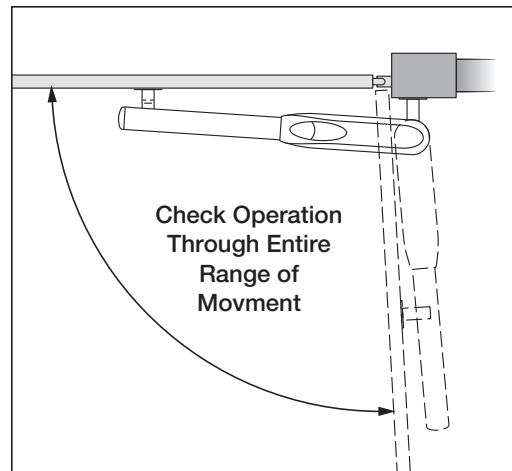

STEP 5

Remount the gate operator. Lubricate the moving parts (the carrier bolt shaft on the lead screw bar, the large and small washer) and tighten the self-locking nut.

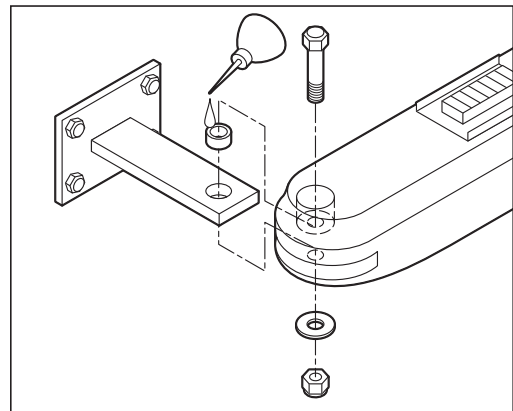
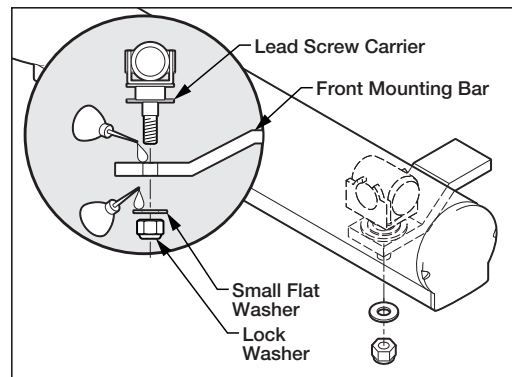

GATE OPERATOR INSTALLATION

Limit Switch Setup

STEP 6

Remove the lead screw cover:

- a) Remove the screw and
- b) Slide out the cover.

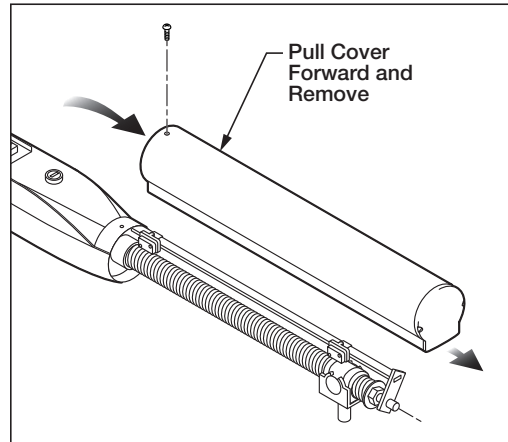

STEP 7

Loosen the screws on the limit switch holders and position the limit switches to the desired position.

Move the gate manually and ensure that the limit switch gets actuated at the desired open and closed position. The limit switch will click when engaged by the lead screw carrier.

Retighten the screws on the limit switch holders once the proper position has been determined (DO NOT OVERTIGHTEN).

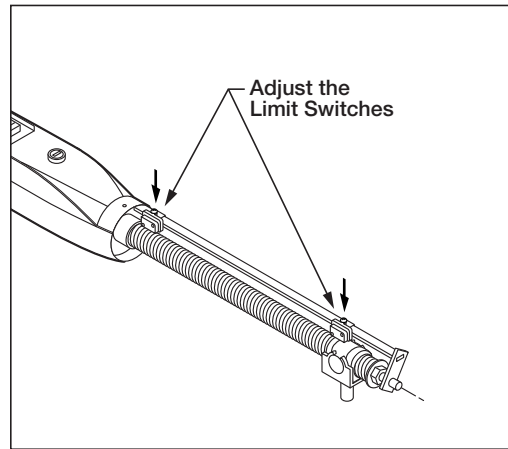

Note: Leave cover off until after the installation of the control box and the electrical installation. Verify that the operator opens and closes to the desired position under power. Make any adjustments as necessary.

STEP 8

Replace the cover taking care to position the shaft properly inside the endcap.

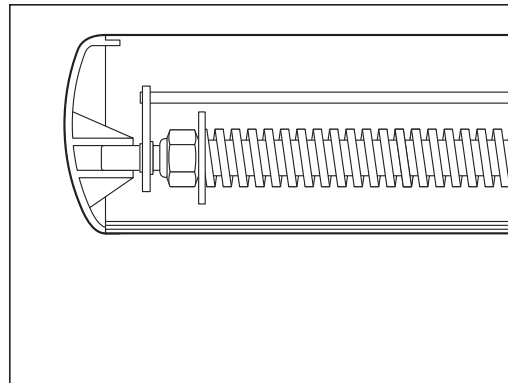

GATE OPERATOR INSTALLATION

Opening/Closing Setup:

To have the gate operator slow down prior to reaching its limits use the following steps:

1. Setup the Limit Switches manually at the desired open and close position.
2. Allow the gate operator to run a full open and close cycle (from limit to limit) without interruption.

Note: During the first full open and close cycle: The gate operator doesn't slow down prior to reaching its limits. During subsequent cycles: The gate operator will slow down prior to reaching its limits.

3. Verify that the gate opens and closes to the desired position.

To change the open or close limit position(s) the following steps MUST BE taken:

A. Reset the gate operator by performing one of the following steps:

- i. Disconnect the Motor/Limit Harness Connector (see page 18 or 19) or
- ii. Actuate both limits at the same time

B. Repeat steps 1,2 and 3.

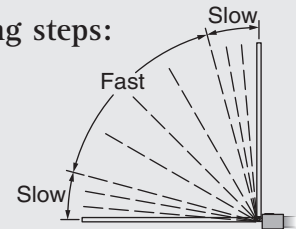

Reference Wiring Diagram

Connect the lead wires as shown

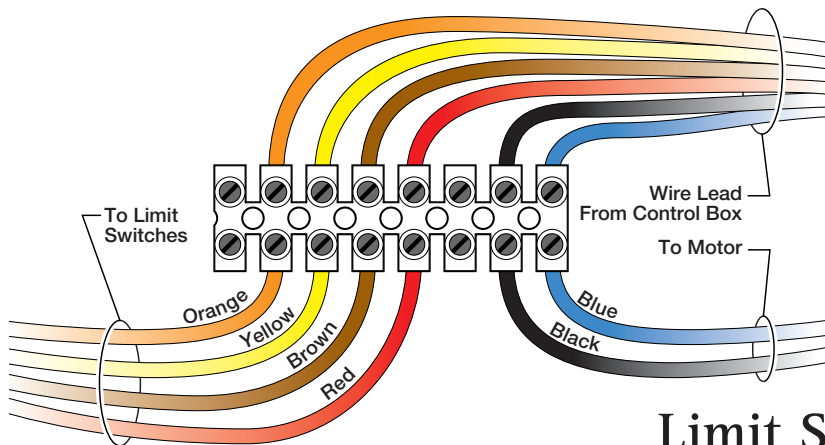

Note: Use this wiring diagram as a guide to connect the wires to the motor unit.

Limit Switch Connections

The Limit Switches are wired as shown

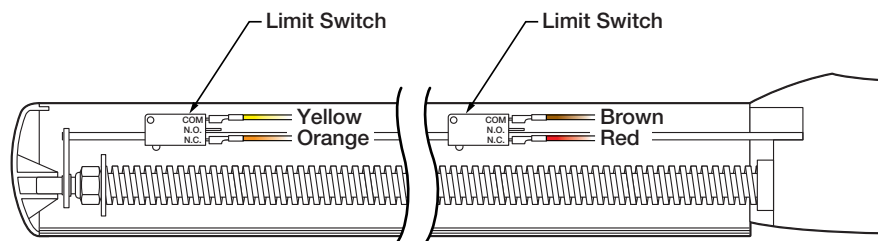

CONTROL BOX INSTALLATION

WARNING - If the control box is not mounted properly it may fall, causing damage and/or injury. The Electronic Control Unit (ECU) weight is approximately 40 lbs. Be sure that the substrate being mounted to and the fasteners being used are appropriate to support the weight of the control box.

1. Disconnect the Siren and Stop Button Leads from the Control Board. Remove the Control Board Mounting Plate. The plate is held in the box by four screws.

2. Position the ECU Box in the desired place and mark the mounting holes. Prepare the holes to receive the anchors/fasteners.

3. Position the ECU Box and secure it to the mounting surface using the Sealed Washers provided (place the rubber side of the washers against the inside of the control box).

Note: Depending on type of anchor used, it may be necessary to enlarge the mounting holes in the control box.

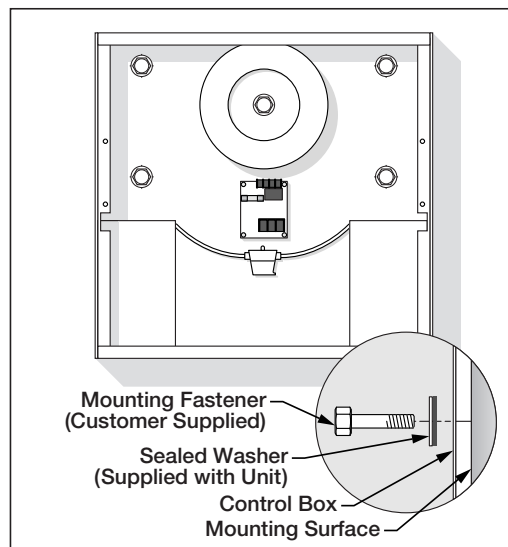
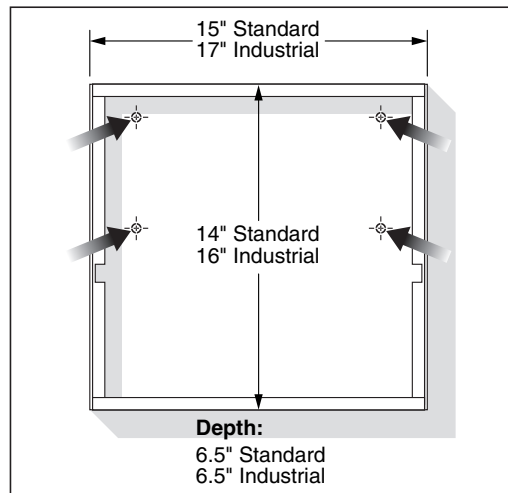
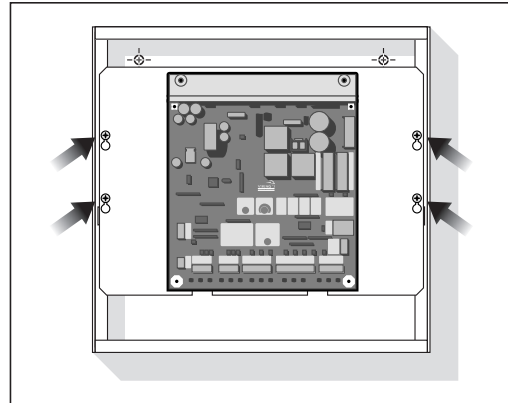

ELECTRICAL INSTALLATION

Caution – Do not connect the power harness to the board until the installation is ready for verification.

The G-5 Gate Operator requires a single phase AC line to operate and charge the batteries.

1. Turn off the main switch or breaker for the power line being used.
2. Move the selector switch on the Incoming Voltage Selector to the proper position (115 for 110 to 120VAC, 230 for 200 to 240VAC).
3. Connect the incoming power wires to the terminals as shown in the illustration.
4. Turn on the main switch or breaker once the installation is ready for performance check and adjustments.
5. To verify that there is AC power to the system, check that the 'Charger' LED on the Control Board is on.

Tips for proper ground installation

A good ground in a gate operator installation will minimize or prevent damage to the operator cause by natural events such as lightning strikes.

The following will provide a guideline for proper grounding:

1. Use a ground rod to provide a ground reference.
2. Consult your city code and be aware of under-ground services in the site of the gate operator to prevent inconveniences.
3. Use always a single bonding point for grounding.
4. All ground wires must be as short and as thick as possible.
5. Prevent unnecessary turns or loops in all ground wires.

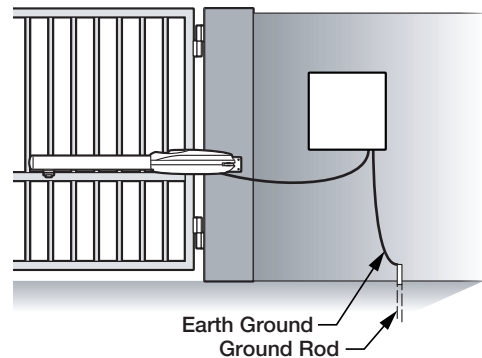
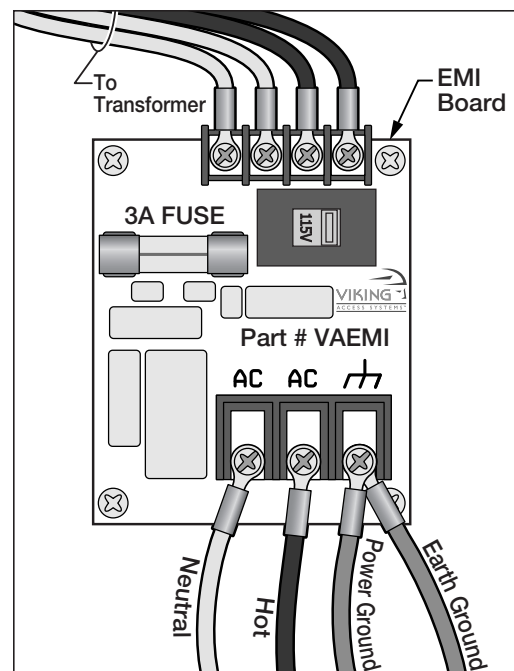
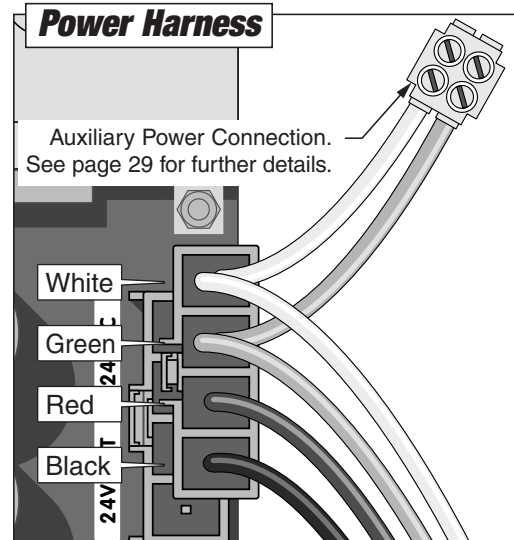

ELECTRICAL INSTALLATION – SINGLE UNIT

Single Unit Connections

Connect the wires from the motor unit to the terminal block mounted next to the control board. Match wire colors to the terminal block.

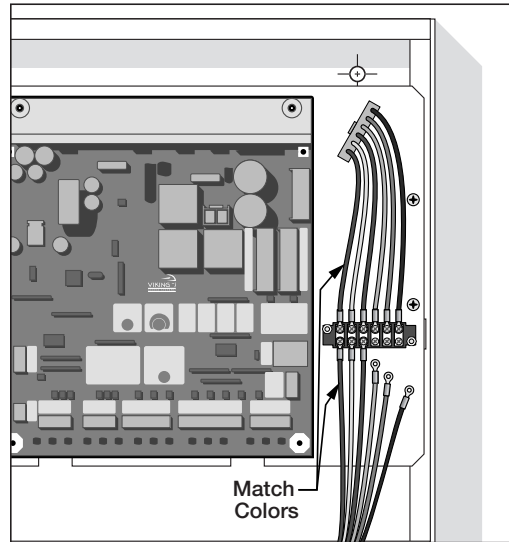

Connect the wire harness to the “OPEN RIGHT” connector if the gate opens inside. Connect the wire harness to the “OPEN LEFT” connector if the gate opens outside.

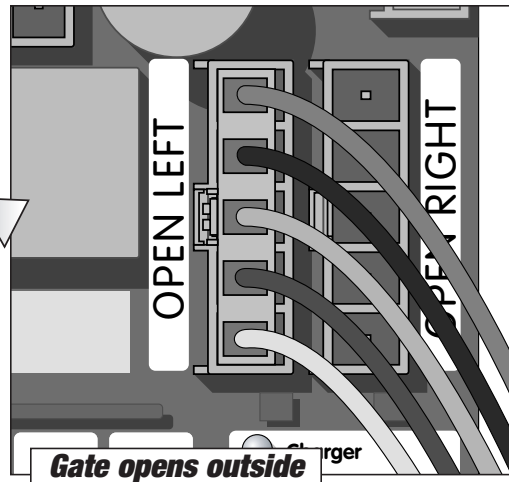
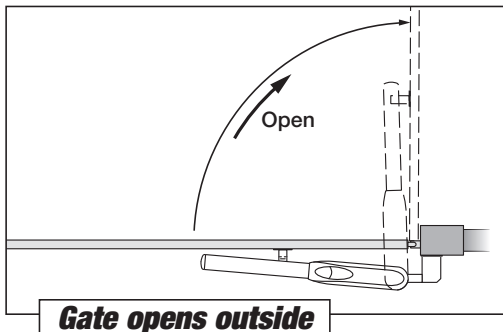
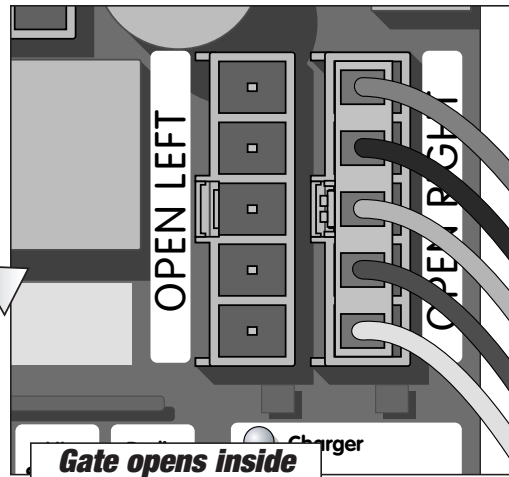
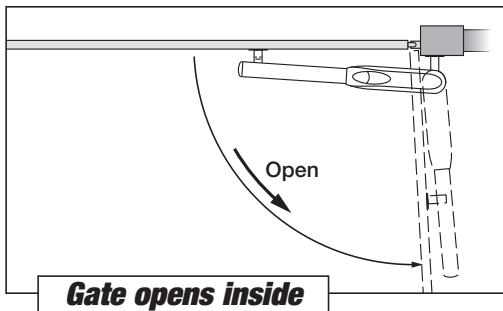

ELECTRICAL INSTALLATION – MASTER/SLAVE

Master/Slave Connections

A Master/Slave control board is available, when required, to run two gate operators in synchronous mode.

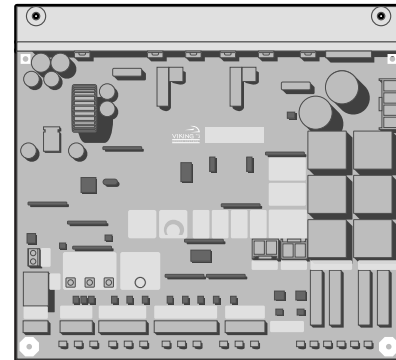

Using the connectors provided insert the wires from the motor units as shown in the diagram below. Insert the connectors in the proper receptacles (Master or Slave, Open Inside or Outside).

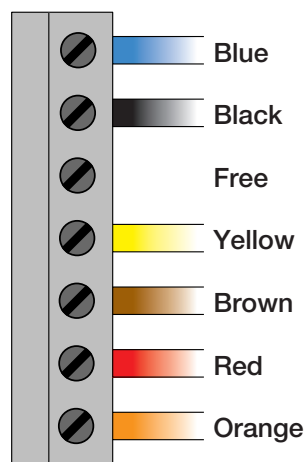
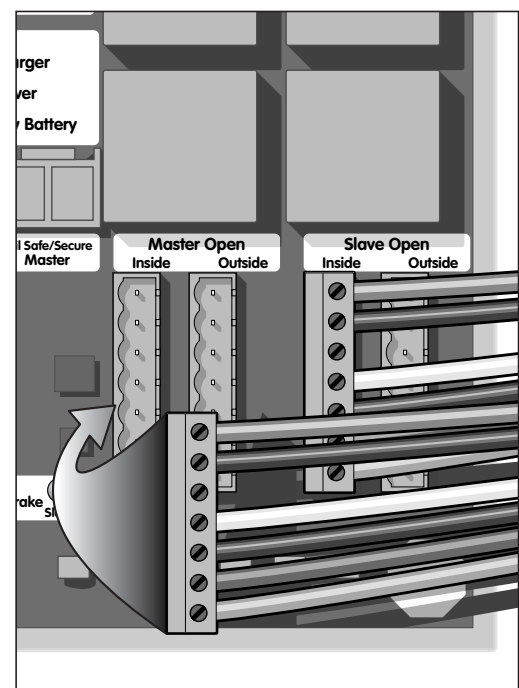

VEHICULAR LOOP DETECTOR INSTALLATION

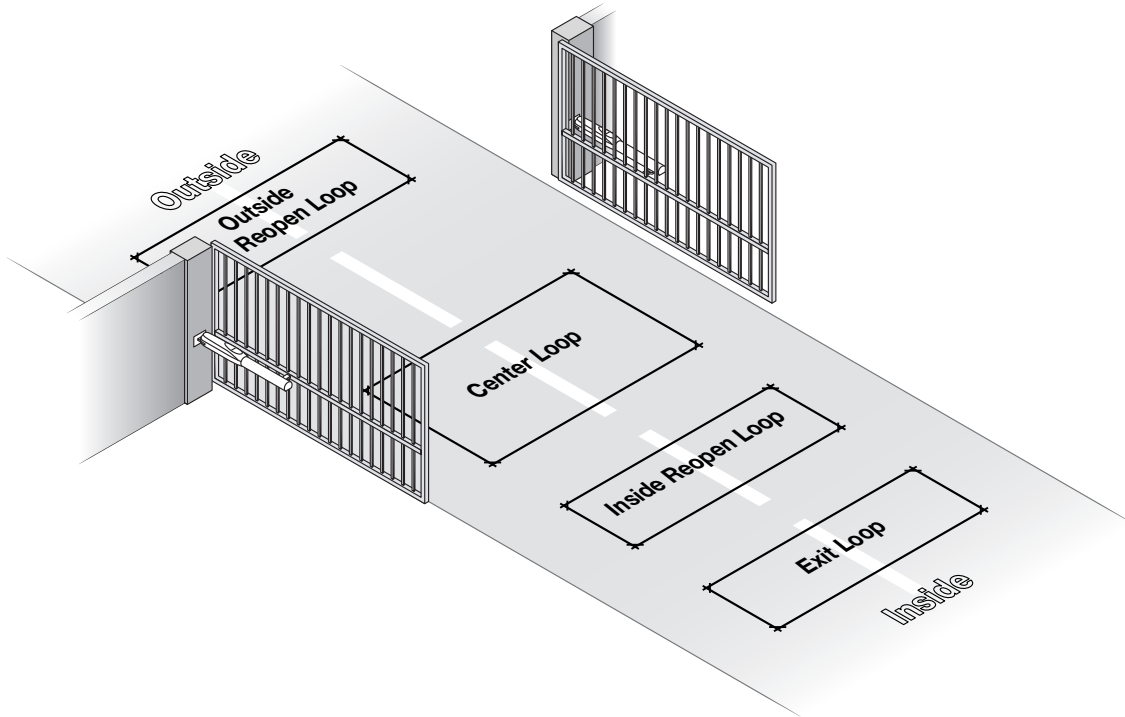

Dimension A – 5' for Single Gate Operator
6' for Master/Slave Gate Operator

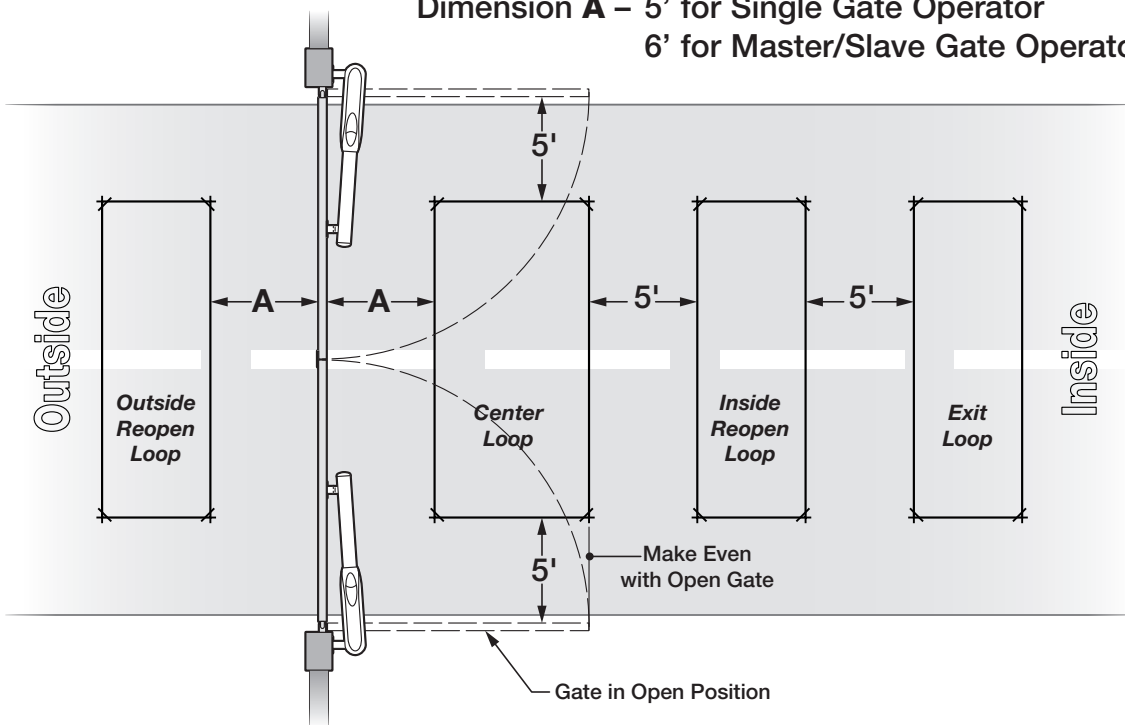

VEHICULAR LOOP DETECTOR INSTALLATION

WARNING – Consult the installation instructions from the loop detector manufacturer. The following statements are provided as a guide but different requirements may be required by the vehicular loop detector manufacturer.

Guidelines for Vehicular Loop Detector Installation

1. Prevent sharp corners in the geometry of the loop sensor.
2. Install the appropriate number of turns for your loop geometry based on the loop perimeter. Use Table C (below) as a guide.
3. Use XLP (cross-linked-polyethylene) type of wire. This wire reduces the effects of moisture and other environmental events in altering the functionality of the vehicular loop detector.
4. Twist the lead wire at least 6 turns per foot.
5. Use BACKER-ROD to minimize damage to the loop detector wire prior to using the sealant.
6. Place the loop detector wire and adjust the sensitivity of the vehicular loop detector unit in a way to minimize the effects of the gate over the loop detector wire.

IMPORTANT – Some of the following parameters may affect the proper functionality of the vehicular loop detector (consult the installation manual and the manufacturer of the vehicular loop detector).

- Gate size,
- Number of turns in the loop sensor wire;
- Distance from the loop sensor wire to the gate either at the open or close position.

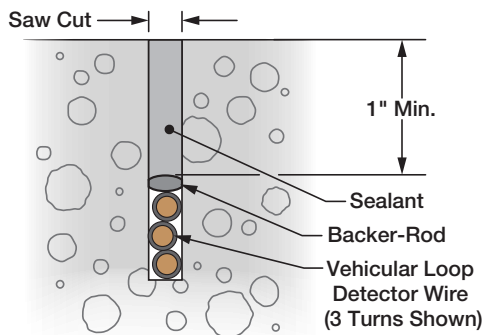
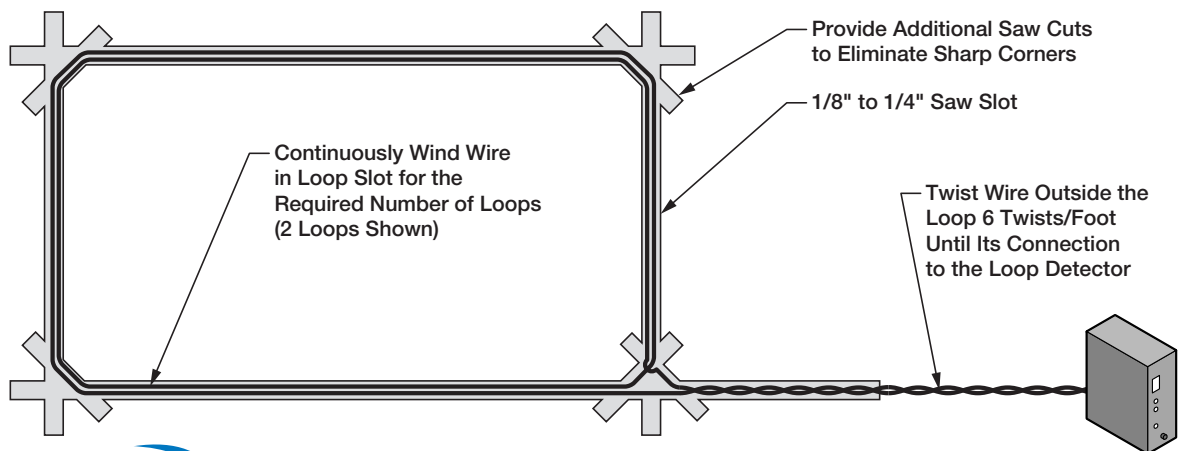
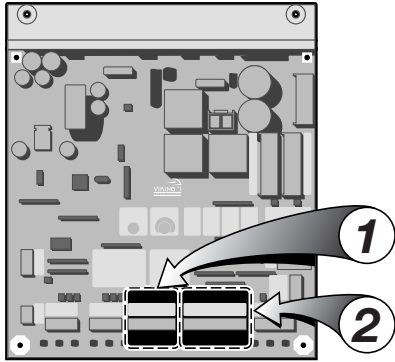

Table C – Recommended Number of Turns

Perimeter in Feet	Number of Turns
10	5
20	4
30-40	3
50-100	2



ACCESSORY CONNECTIONS



Connection Locations
(Single Unit Board shown)

Vehicle loop detectors must be installed to decrease the possibility of vehicle entrapment on the gate (see page 20).

The SECONDARY ENTRAPMENT PROTECTION like the edge sensor and the photoelectric beam MUST BE PART OF EVERY SINGLE INSTALLATION to prevent pedestrian or animal entrapment (see pages 6 and 7).

The edge sensor and/or the photoelectric beam must be UL325 compliant devices.

Open Commands

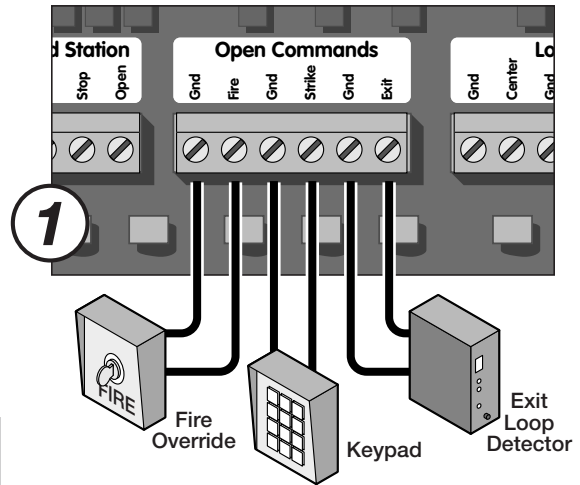

Safety Connections

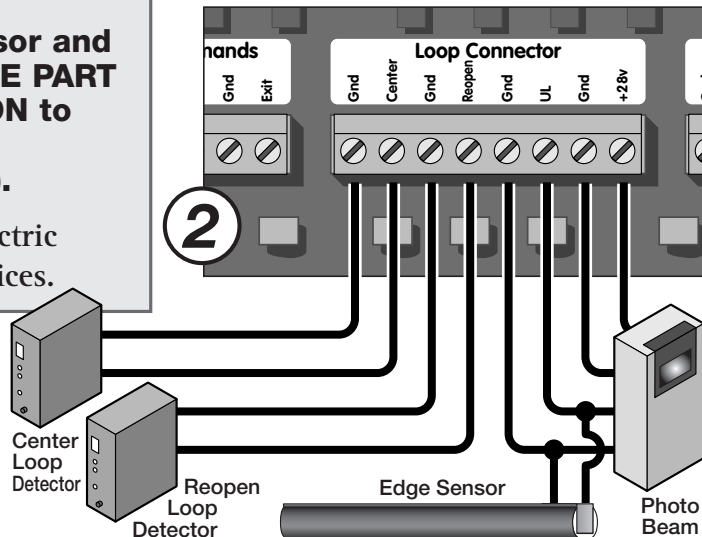

Reopen Photo Beam

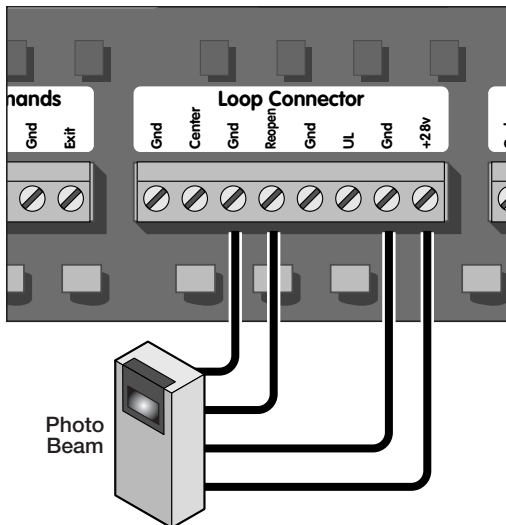

As an alternative to the Outside Reopen Loop, a photo beam unit can be used as shown.

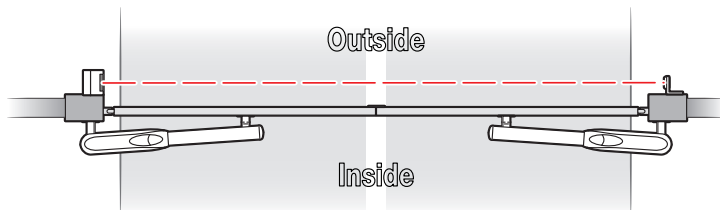

ACCESSORY CONNECTIONS

Radio Receiver

When connecting the Radio Receiver carefully verify the proper connections.

The maximum voltage that the control board provides for external accessories is the maximum voltage of the battery, which is about 28 volts.

In the event of an electrical short in the power to the accessories, the board will protect itself by shutting down and will remain shut down until the short is corrected.

The control board provides two modes of operation that a radio receiver can control the gate:

Open-Stop-Close

1. By having the radio receiver connected as illustrated and with the Hold Open Timer OFF (see page 27):

Every command of the radio transmitter will control the gate as follow:

- a) First command opens the gate,
- b) Second command stops the gate and
- c) Third command closes the gate
- d) Any subsequent commands will continue in the same order to control the gate.

This type of configuration is not recommended for a commercial installations.

Open Only

2. By having the radio receiver connected as illustrated and with the Hold Open Timer ON (see page 27):

Each command of the radio transmitter is ALWAYS AN OPEN COMMAND to the gate.

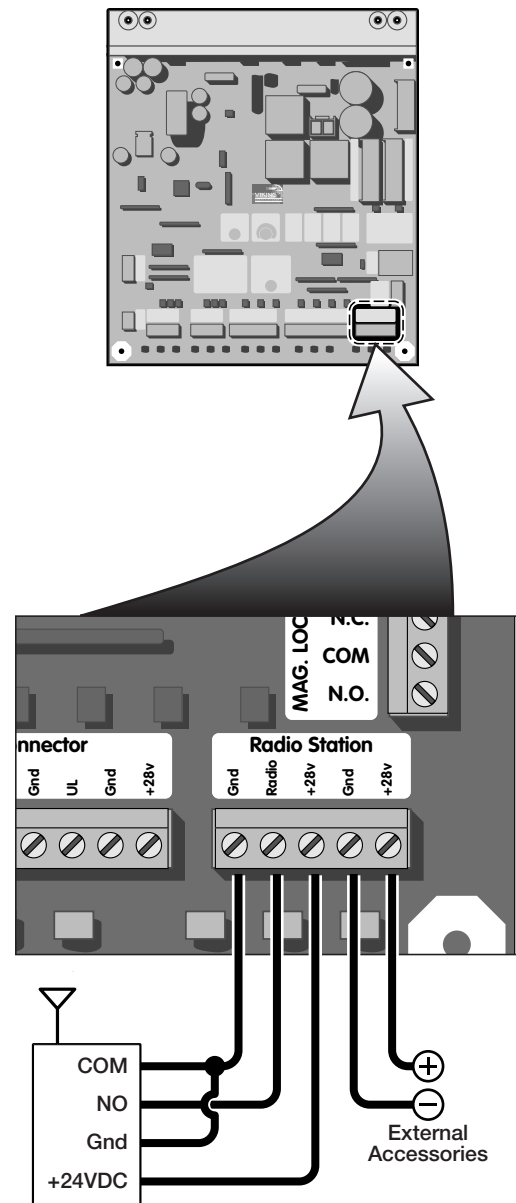



VIKING ELECTROMAGNETIC LOCK

Standard Features

- Mounting base with electrical box
- 24VDC Plug-in transformer
- 12VDC or 24VDC operation
- 500mA at 12VDC operation
- 250mA at 24VDC operation
- 1300 pounds of holding force

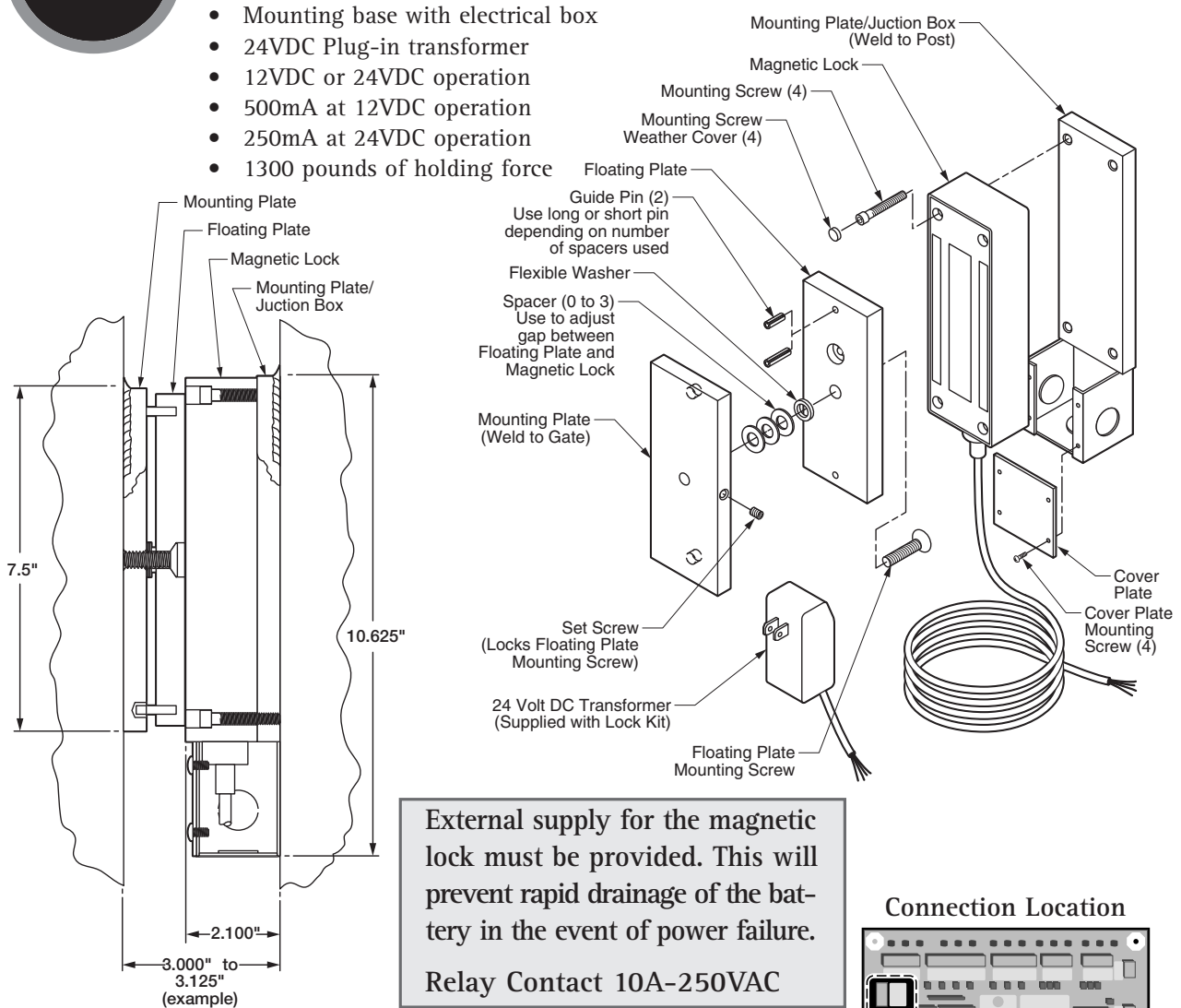

External supply for the magnetic lock must be provided. This will prevent rapid drainage of the battery in the event of power failure.
Relay Contact 10A-250VAC

Connection Location

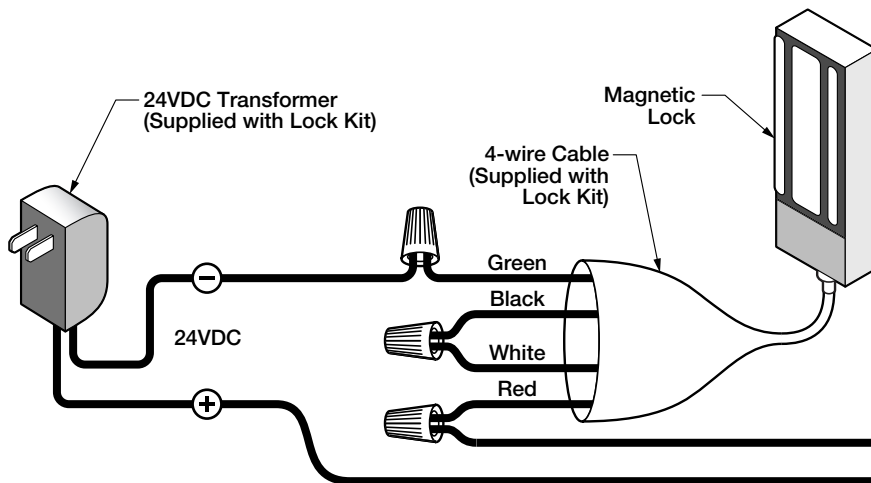
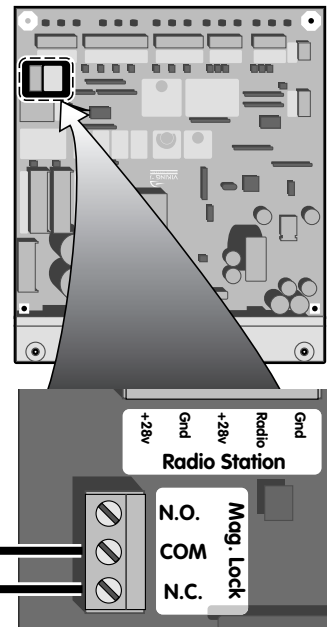

This Magnetic Lock is an **OPTIONAL ACCESORY** available from Viking Access Systems. Please order part number VA-MAG13.



ACCESSORY CONNECTIONS

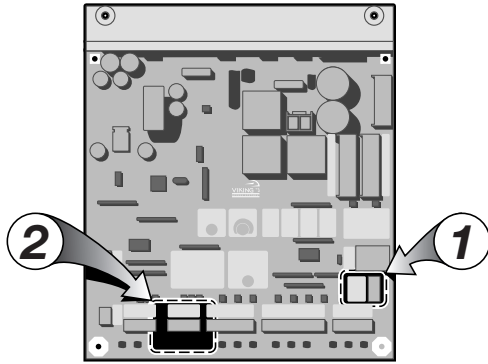

Connection Locations
(Single Unit Board shown)

Viking Access Systems can supply an excellent Magnetic Lock unit (part number VA-MAG13). See page 24 for more details.

Magnetic Lock

External supply for the magnetic lock must be provided. This will prevent rapid drainage of the battery in the event of power failure.

Relay Contact 10A-250VAC

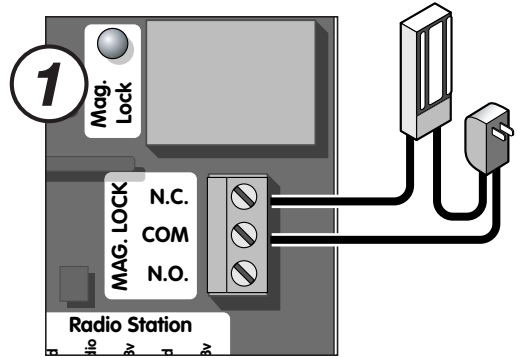

Solenoid Connection

External supply for the solenoid connection must be provided. This will prevent rapid drainage of the battery in the event of power failure.

Relay Contact 10A-250VAC

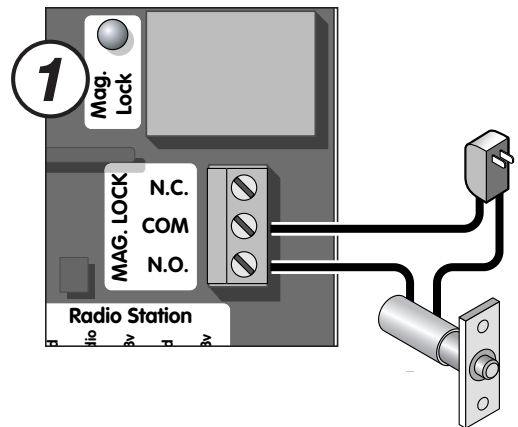

Guard Station

The guard station provides control of the gate operator to open, stop and close the gate.

All three switches must be Normally Open type of switch, and can share the same common (ground).

Place the control switch box within sight of the gate, away from moving parts of the gate and out of reach of children.

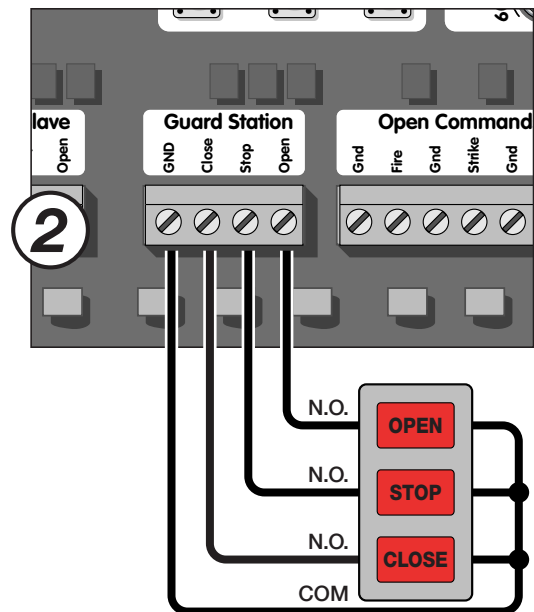

SPECIAL FEATURES

Intelligent Obstruction Sensor (Primary Entrapment Protection)

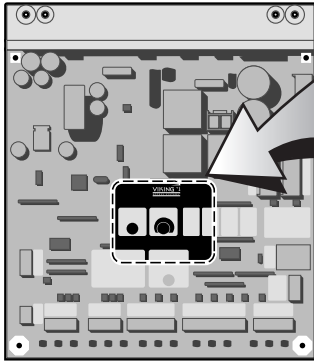

Trim Pot Location
(Single Unit Board shown)



The Obstruction Sensor detects obstructions in the path of the traveling gate. The Trim Pot for the Obstruction Sensor adjusts the sensitivity level that triggers the Sensor.

When the Obstruction Sensor detects an obstruction it will:

1. Stop the gate's movement and reverse it momentarily.
2. Bring the gate to a resting position.
3. Disable the Hold Open Timer feature until the Gate Operator receives a new command.

If another obstruction is detected before the gate reaches either limit it will:

1. Stop the gate's movement.
2. Bring the gate to a resting position.
3. Disable the Gate Operator.

UL325 standard requires an audio alarm to go off after two consecutive entrapment events sensed by the Inherent Entrapment Protection of the Gate Operator.

The audio alarm will sound for a period of 5 minutes or until the "Stop" Button is pressed (see page 8 for remote installation of a "Stop" Button).

Turning the Trim Pot clockwise increases the sensitivity.

Turning the Trim Pot counter-clockwise decreases the sensitivity.

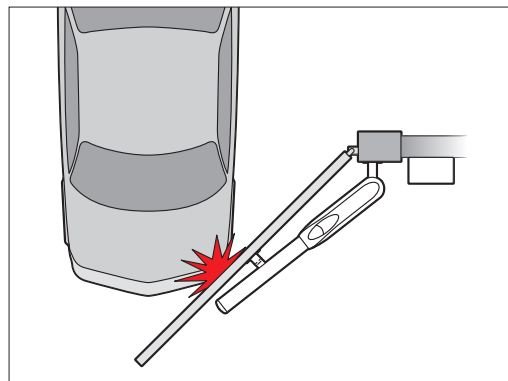

SPECIAL FEATURES

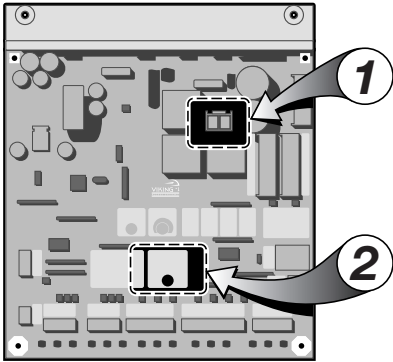

Connection Locations
(Single Unit Board shown)

Fail Safe/Fail Secure Operation

The gate operator contains a unique design that allows the user to move the gate manually in case of power failure.

There are three levels of force required to move the gate manually.

Minimum Force:

By removing the wire-jumper plug from the “Fail Safe/Secure” connector:
The gate can be move manually with relative low amount of force.

Maximum Force:

By inserting the wire-jumper plug into the “Fail Safe/Secure” connector:
The gate can still be move by hand with relative high amount of force.

Manual Operation Locked

By removing the “Break Release Pin” from the operator:
The gate can’t be moved manually.
Caution: If the gate is moved manually, damage may occur to the operator and/or the gate system.

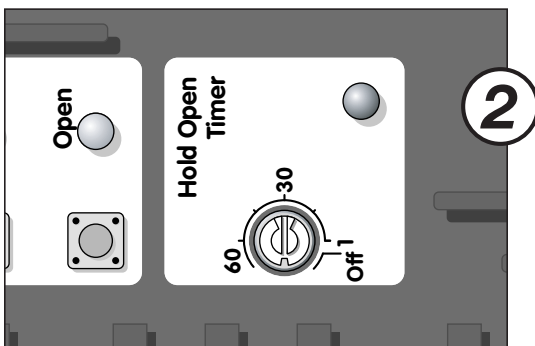
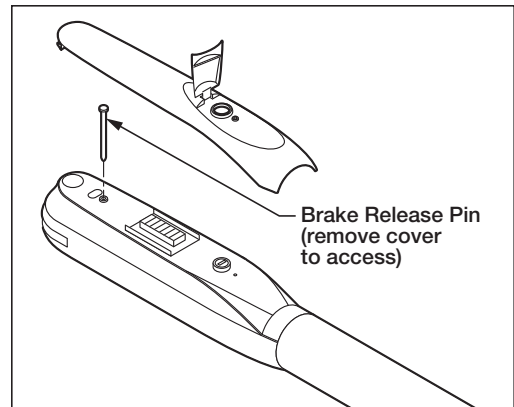
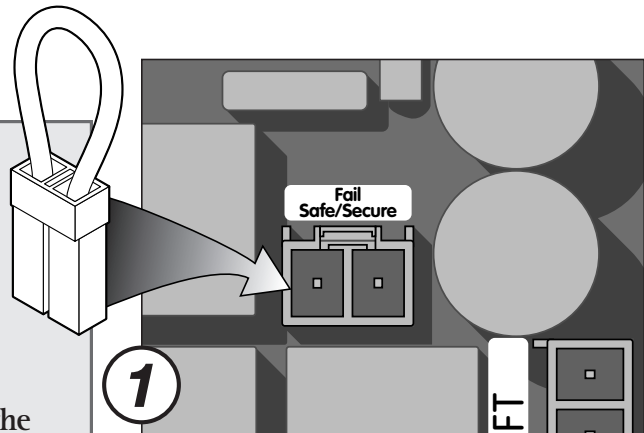

Hold Open Timer

The Hold Open Timer function holds the gate at the open position for a predetermined amount of time, prior to closing automatically. Set the Timer to the desired time, from 1 to 60 seconds.

If this feature is not needed, turn the Trim Pot clockwise to the “off” position.

Note: The Hold Open Timer affects the “radio receiver command” and the sequence of operation for the gate (see page 23).



SPECIAL FEATURES

Gate Overlap Setting

Setting the Overlap Delay Pot to “0” will cause the master and the slave units to open and close at the same time

A Master/Slave control board is required to operate two gates with a single controller.

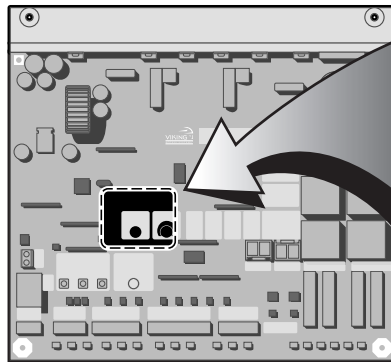

Trim Pot Location
(Master/Slave Unit Board shown)

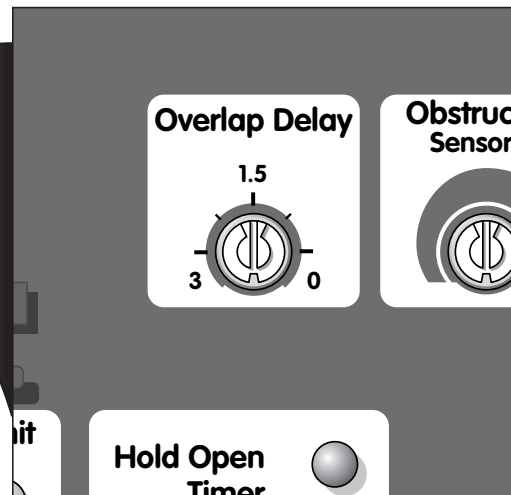

Setting the Overlap Delay Pot to any value other than zero will cause the master unit to delay in opening.

The time delay can be set for up to 3 seconds.

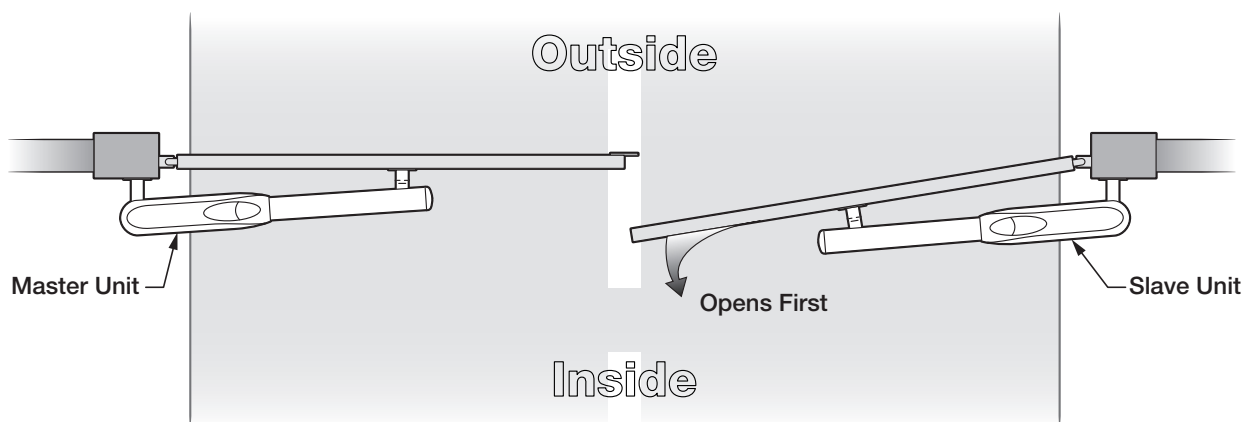

SOLAR PANEL INSTALLATION

For Viking Vehicular Gate Operators

STEP 1

Use a 24V solar panel or two solar panels of 12V in series with a total capacity of 40 Watts..

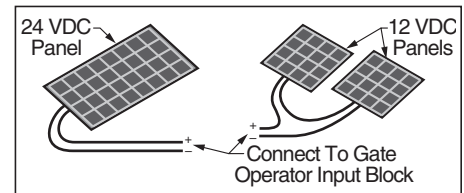

STEP 2

Connect the solar panel cables to the power harness as shown. Make sure you cut the wires coming from the toroidal transformer.

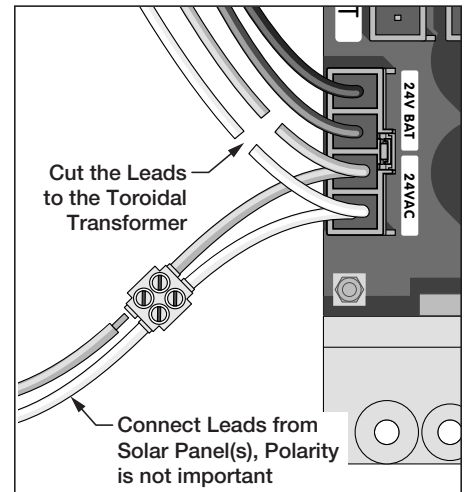

STEP 3

Replace the existing batteries with a battery pack of 33Ahr or greater.

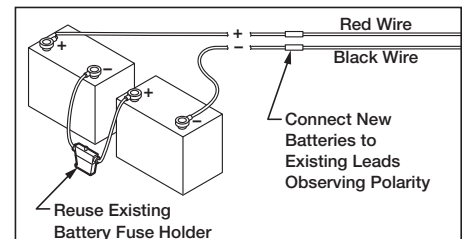

STEP 4

Refer to the maps provided to get an idea about the number of cycles the gate will be operated per day. This figure is for a single gate operator with just:

- One Radio reiver,
- One low voltage low current loop detector and
- One low voltage, low current photo cell

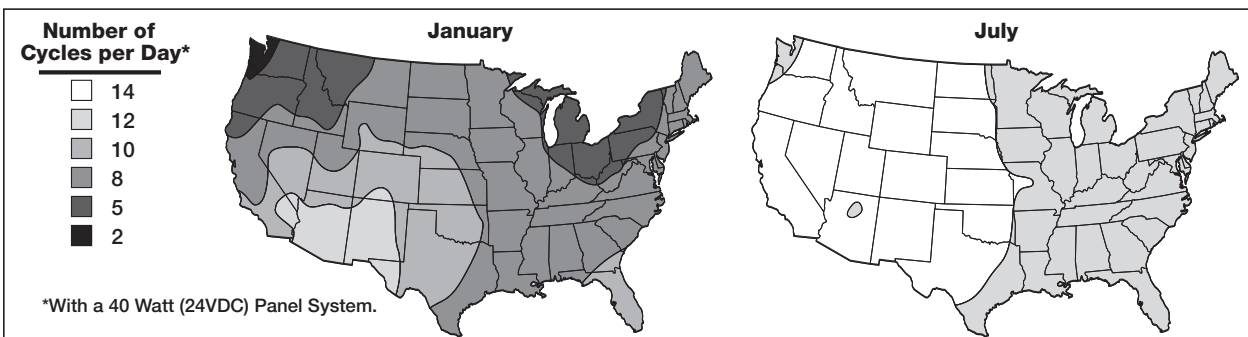

NOTE -

- Remember that the sun is your only source of energy.
- The greater capacity of the batteries, the longer the system will operate on cloudy days.
- If more specific information is needed, please consult with Viking Access Systems. For more information regarding solar energy refer to <http://www.nrel.gov>.





These Hinges are **OPTIONAL ACCESORIES** available from Viking Access Systems. Please order part number VA-HD.

Standard Features

- Self-lubricating oil impregnated bronze bushing
- Port for adding a Zirk fitting
- 3000 lbs. capacity per pair
- Heat-treated stainless steel pin

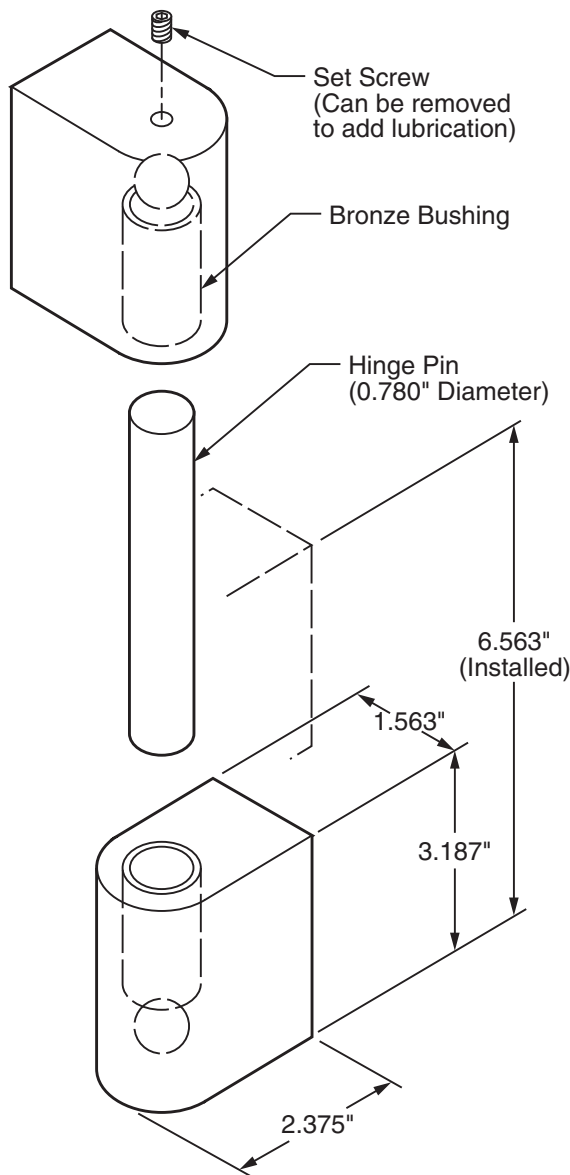

TROUBLESHOOTING

Gate does not run – Motor Sensor indicator comes ON

Check all motor connections to be fully engaged. Refer to page 15, 18 and 19.

Ensure that the motor connections are:
 a) Properly connected,
 b) Tight enough and
 c) Color coded
 Refer to page 15.

Check that all motor cable connections, junctions and extensions are properly connected and color-coded. Refer to page 15.

Check the 15 Amp fuse in the control board

Gate does not run – Motor Sensor indicator is OFF

Check all motor connections to be fully engaged. Refer to 15.

Check that limit switches are connected to the common and the normally close position refer to page 15.

Check that the stop command is not active. Refer to page 8 and 25

Check that the UL command (photo beam and/or edge sensor) is not active. Refer to page 6, 7 and 22.

Check that the vehicular loop detectors are working properly. Refer to page 20, 21 and 22.

Check that the radio command is not active. Refer to page 23.

Ensure that you external accessories are working properly.

Check the 4 Amps fuse in the control board

Ensure that you power cables are adequate in voltage and properly connected. Refer to page 17.

Gate does not run – Power failure

Check the 15 Amp battery fuse. Refer to page 16

Check the battery connections and cables.

Check the voltage of the battery.

Gate does not run – Obstruction sensor ON and audio alarm is SOUNDING

Ensure that the gate path is clear of obstructions.

Note: To stop the audio alarm, use the stop command. Refer to page 8 and 25.

Adjust the trim pot of the obstruction sensor. Refer to page 26.

Gate runs, stops and reverse momentarily – Obstruction sensor ON and audio alarm OFF

Ensure that the gate path is clear of obstructions.

Check for proper functionality and lubrication of the gate and hardware (hinges and the like).

Adjust the trim pot of the obstruction sensor. Refer to page 26.

Gate ignores the limit switches

Check that the open limit switch and close limit switch are in the corresponding place. Refer to page 15.

Check that all motor cable connections, junctions and extensions are properly connected and color-coded. Specifically check the blue and black motor leads. Refer to page 15.

Ensure that the motor cable is away from sources of electrical interference, such as
 a) Electric motors
 b) Electric fences
 c) Power lines

Check that the limit switch is not faulty

Check that wires to the limit switch are not shorted.

Note: To minimize effects cause by electrical interference use twisted pairs of cables with the shield grounded.



TROUBLESHOOTING

Gate does not open or close

Check all motor connections to be fully engaged. Refer to page 15.	Check that limit switches are connected to the common and the normally close position refer to page 15.	Check that the stop command is not active. Refer to page 8 and 25.
Check that the UL command (photo beam and/or edge sensor) is not active. Refer to page 6, 7 and 22.	Check that the vehicular loop detectors are working properly. Refer to page 20, 21 and 22.	Check that the radio command is not active. Refer to page 23.
Ensure that you external accessories are working properly		

Automatic Hold Open Timer does not function

Check that the trim pot of the hold open timer is set to the proper time delay. Refer to page 27.	Note: Hold open timer closes the gate automatically once the gate reaches the limit open. The time delay to close is set by the trim pot. To turn this system off turn the trim pot all the way clockwise.	Verify proper functionality of: Photo beam(s) Loop Detectors Radio Receiver that may prevent closing the gate.
---	--	--

Gate opens in the opposite desired direction

Verify your motor cable is connected to the proper connector. Specifically check the blue and black motor leads. Refer to page 18 and 19.	Check that all motor cable connections, junctions and extensions are properly connected and color-coded. Refer to 15.
---	---

Gate opens in the opposite desired direction passing the limit switch

Check the motor wiring and polarity of cables. Refer to page 18 and 19.

On a Master/Slave installation, one gate runs in the opposite direction

Check the motor and limit switch wiring. Refer to page 15 and 19.	Verify that both units are connected as open-left or open-right. Refer to page 19.
---	--



TROUBLESHOOTING

Gate opens after few second delay

Set the overlap delay trim pot to 0. Refer to page 28.

Note: Overlap trim pot is normally recommended to use in overlapping gates. Refer to page 28.

Gate opens. Closes or stops on its own

Ensure that the key for manual release is in the lock position. Refer to page 7.

Make sure that the 'Charger' LED is on, indicating that there is AC power.

G-5 unit runs slower than normal

Set the overlap delay trim pot to 0. Refer to page 28.

Note: Overlap trim pot is normally recommended to use in overlapping gates. Refer to page 28.

'Charger' LED off. Gate does not run - alarm sounds upon any input command

Check the 4 Amp fuse on the control board.

Check the 3 Amp fuse on the EMI control board. Refer to page 17.

Make sure the incoming AC line is properly connected. Refer to page 17.

Check the incoming high voltage power supply.

Check the proper selection of power supply (120/220 VAC). Refer to page 17.

Verify the EMI board by reading high voltage across the (4) blue and red wires at the terminal block connections.

Battery voltage reads zero or very low

Ensure the batteries are connected as follows:

- a) Left battery - Black terminal connected to the black wire from the harness (jacketed wire)
- b) Left battery - Red terminal connected to the red wire from fuse holder
- c) Right battery - Black terminal connected to the red wire from fuse holder
- d) Right battery - Red terminal connected to the red wire from the harness (jacketed wire)



UL325 and UL991 Listed by Underwriter Laboratories (UL)

Accessible manual release via key operated mechanism

Fail-Safe option sets the gate to automatically transfer to a fail-safe mode in the event of a power failure, allowing the gate to be pushed open without the use of special knowledge of the equipment.

Fail-Secure option sets the gate to mechanically lock in the event of a power failure, allowing no manual movement without the use of the manual release.

Elegant design, appealing to any architectural project.

Powder coated aluminum housing.

Opening up to 120°.

Operation speed of 16 to 18 seconds per 90°.

100% duty cycle under very wide temperature range.

Very low power consumption.

400 cycles of operation on backup battery (600 lb. gate and 12' length).

Intelligent speed control with smooth start and stop, self-adjust system.

Modulated speed regulator prevents exceeding operating speed that may reduce the service life of the gate operator and/or installation.

Intelligent obstruction detection with adjustable sensitivity.

Overlap delay that holds one gate momentarily by an adjustable time while the other gate is operating
(Master/Slave installation with overlap gates).

Built-in protection against lightning strikes or similar electrical surges.
Inherent overload protection in the regulated power supply for external accessories with multiple devices of protection.

Modular connectors for easy installation.

Solar panel and low voltage wiring compatibility.

LED indicators for verification of operation.



Viking Access Systems
T 800.908.0884 • F 949.753.1640
631 Wald - Irvine, CA 92618

vikingaccess.com